



With partners across China and the world,
NORTH has a truly national and international
understanding and unparalleled collective expertise.

Jinan North Welding & Cutting Tools Co Ltd
济南诺斯焊割辅具有限公司
No.25 XinMaoQiLu Sci-tech Zone Zidong Road Tianqiao Zone Jinan 250121
Shandong, P.R. China
中国山东省济南市天桥区桑梓店鑫茂齐鲁科技城25号
China Sales (销售部) : 0531 8801 0828 /0531 8866 7989
Fax (传真) : 0531 88662278

Cutting Torch Series for Everyone [™]
northweld.com

All Trademarks / Part Numbers printed in this catalogue are the property of their respective owners and are for reference purposes only. All Trademarks / Part Numbers are in no way connected or affiliated with Jinan North Welding & Cutting Tools Co Ltd. Specification / Product Information / Product Appearance are subject to change without notice. Please refer to www.northweld.com for the most up-to-date data.

NC004-01-0422

济南诺斯
Jinan North

PLASMA TORCHES

HIGH PERFORMANCE GUARANTEE

**Ready for action.....
whatever work throws at it**



NO HF NS Range NS 系列低频等离子割枪

NS 25	3
NS 25K	5
NS 35K	7
NS45	9
NS 65	11
NS 75	13
NS 80	15
NS 105	17
NS 125	19

HF NA Range NA 系列高频等离子割枪

NA 81	22
NA 101	24
NA 141	26
NA 151	28

HF CB Range CB 系列高频等离子割枪

CB 50	31
CB 70	33
CB 100	35
CB 150	37

HF NP Range NP 系列高频等离子割枪

PT 31	40
SG 55	42
AG 60	44
NP 80	46

NO HF NU Range NU 系列低频等离子割枪

NU 30K	49
NU 45	51

NO HF NSP Auto Range NSP 系列低频自动等离子割枪

NS 75P	54
NS 80P	56
NS 105P	58
NS 125P	60

HF NAP Auto Range NAP 系列高频自动等离子割枪

NA 81P	63
NA 101P	65
NA 141P	67
NA 151P	69

HF CBP Auto Range CBP 系列高频自动等离子割枪

CB 100P	72
CB 150P	74

HF NW Range NW 系列高频等离子割枪

NW 130P	76
NW 160P	76
NW 200P	77

Cable and Wiring System 插接头适配

Cable Fitting Options	79
Central Adaptor System	80

HF-High Frequency 高频等离子割枪

NO HF-Without High Frequency 低频等离子割枪

Plasma Cutting Torch

NS	 <p>NS25 25A 60%</p>	 <p>NS25K 20A 35%</p>	 <p>NS35K 32A 35%</p>	 <p>NS45 40A 60%</p>
	 <p>NS65 60A 60%</p>	 <p>NS75 70A 60%</p>	 <p>NS80 80A 60%</p>	 <p>NS105 100A 60%</p>
	 <p>NS125 120A 60%</p>			
NA	 <p>NA81 80A 60%</p>	 <p>NA101 100A 60%</p>	 <p>NA141 140A 60%</p>	 <p>NA151 150A 60%</p>
CB	 <p>CB50 50A 60%</p>	 <p>CB70 70A 60%</p>	 <p>CB100 100A 60%</p>	 <p>CB150 150A 60%</p>
NP	 <p>PT31 30A 60%</p>	 <p>SG55 60A 60%</p>	 <p>AG60 60A 60%</p>	 <p>NP80 80A 60%</p>

NU	 <p>NU35K 30A 35%</p>	 <p>NU45 40A 60%</p>		
CBP	 <p>CB100P 100A 60%</p>	 <p>CB150P 150A 60%</p>		
NSP	 <p>NS75P 70A 60%</p>	 <p>NS80P 80A 60%</p>	 <p>NS105P 100A 60%</p>	 <p>NS125P 120A 60%</p>
NAP	 <p>NA81P 80A 60%</p>	 <p>NA101P 100A 60%</p>	 <p>NA141P 140A 60%</p>	 <p>NA151P 150A 60%</p>
NW	<p>Coming Soon...</p>			
	 <p>NW130</p>	 <p>NW160</p>	 <p>NW200 200A 100%</p>	

Without High Frequency 高频等离子割枪

High Frequency 高频等离子割枪





NS Range



CNC 精密加工及高质量工程材料。
CNC machined consumables part and aerospace polymers.



人机工学设计，实用、耐用型枪壳。
Ergonomic, solid handle design.



增加安全防护板，避免意外发生。
A mechanical lever fitted to the trigger for user safety.



可适配多种后尾接头。
Terminations are offered in a "direct to machine" or central connector configuration.

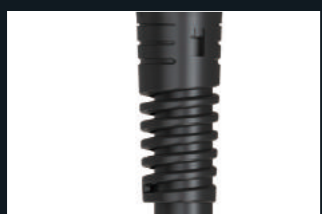

灵活的支撑设计。
Spiral design helps support the cable and offer great all day comfort use.



Technical Data 参数	NS 25	NS 25K	NS 35K
Cooling Method 冷却方式	Air-Cooled	Air-Cooled	Air-Cooled
Rating : 额定电流	25A	20A	32A
Duty Cycle: 暂载率	60%	35%	35%
Cutting Thickness: 切割厚度	6-8mm	4-6mm	6-8mm

Without High Frequency 低频等离子割枪

Order Part No.	1/4G	4M	NPA0411G	NPA0408G	NPA0409G
		5M			
CENTRAL ADAPTOR		4M			
		5M			
		6M			



NS 45	NS 65	NS 75	NS 80	NS 105	NS 125
Air-Cooled	Air-Cooled	Air-Cooled	Air-Cooled	Air-Cooled	Air-Cooled
40A	60A	70A 50A	80A 60A	100A 70A	120A 90A
60%	60%	60% 100%	60% 100%	60% 100%	60% 100%
8-12mm	8-20mm	18-23mm	20-30mm	25-30mm	10-35mm

NPA0165G	NPA2201G	NPA1606G	NPA8606G	NPA1654	NPA2251
NPA0166G	NPA2200G	NPA1604G	NPA8604G	NPA1652	NPA2250

NS 25

额定值: 25A 60% 暂载率。切割厚度: 6-8mm。
Rating: 25A 60% duty. Cutting Thickness: 6-8mm.

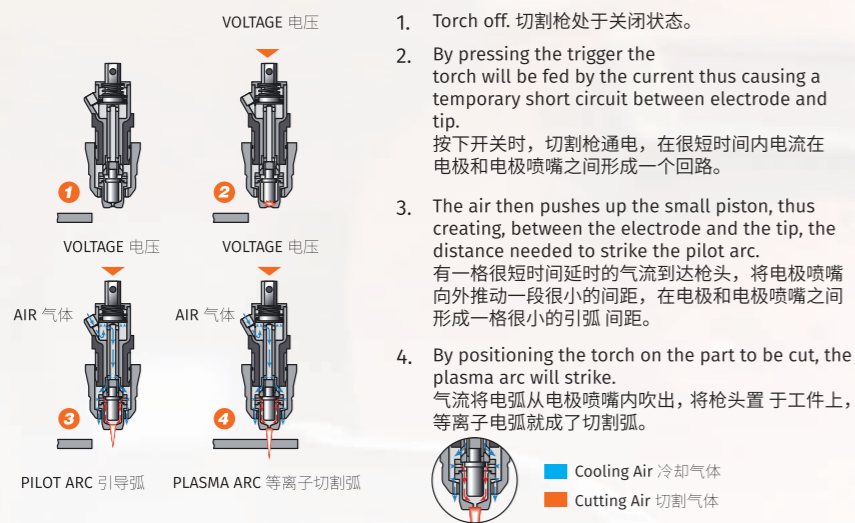

Model 型号					
Description 描述	Length 长度	Part Number 编号			
NS25 1/4G 接口 Plasma Cutting Torch	4m	NPA0411G			
Components					
No.	Part Number	Description	No.	Part Number	Description
1	NCV0010-A	Spacer Spring 隔离簧	8	NBX0628	Trigger Button 扳机按钮
2	NPC0116	Outside Nozzle 外喷嘴	9	NBW0243BG	Handle 双色手柄
3	NPD0116-06	Cutting Tip 20A 电极喷嘴	10	NBW0246	Handle Locking Nut 手柄锁扣
	NPD0116-08	Cutting Tip 30A 电极喷嘴	11	NPH0281	Cable Assembly 4m 4m 电缆总成
	NPD0116-09	Cutting Tip 40A 电极喷嘴	12	NCY0002	Back Cable Support 后尾护套
4	NPE0106	Swirl Ring 涡流环	13	NBW0195	Back Handle 后枪壳
5	NPR0110	Electrode 电极	14	NBW0174	Locking Nut 中央插头锁母
	NPF0125	Torch Head Kit 枪头	15	NFY0018G	Central Connector 中央插头
7	NBX5833CH	Safety Trigger 扳机 (橙黑)			

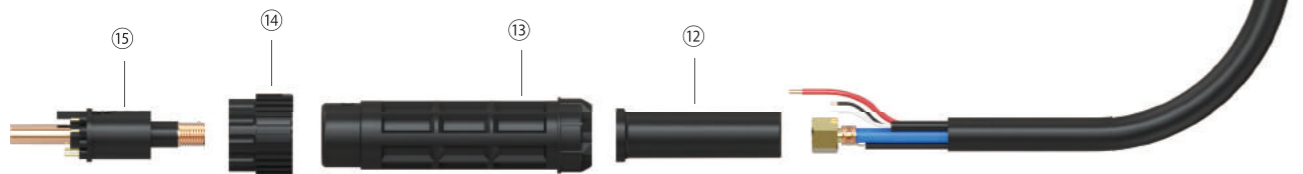

NS 25 WEAR PARTS

All our consumable parts are interchangeable with the original OEM specification
Production Materials sourced from qualified top tier supplier (s).

NO.	Part Number	Description	Φ(mm)	L(mm)	Contact Short	Contact Long	Drag Short	Drag Long	Gouging	Product picture
1	NCV0010-A	Spacer Spring		22.5	●					
	NCV0010N	Double Pointed Spacer	25	22	●					
	NCV0024	Buggy	23.5	33	●					
	NCV0007	Shield Cap				●				
2	NPC0116	Outside Nozzle		28	●	●				
	NPC0110	Shield Cap Body		26.2	●		●			
3	NPD0116-06	Cutting Tip 20A	0.65	17.3	●					
	NPD0116-08	Cutting Tip 30A	0.8	17.3	●					
	NPD0116-09	Cutting Tip 40A	0.9	17.3	●					
	NPD0103-65	Cutting Tip 20A	0.65	25.8	●					
	NPD0103-09	Cutting Tip 40A	0.9	25.8	●					
4	NPE0106	Swirl Ring			●					
5	NPR0110	Electrode		21.8	●					
	NPR0106	Electrode		30.5	●					

● Torch Package Standard Wear Part Set Up 包装标准配件
 Contact Short
 Contact Long
 Drag Short
 Drag Long
 Gouging

* Denotes Standard Build 表示标准配置, 选配件须注明编号

NS 25K

额定值：20A 35% 暂载率。切割厚度：4-6mm。
Rating: 20A 35% duty. Cutting Thickness: 4-6mm.

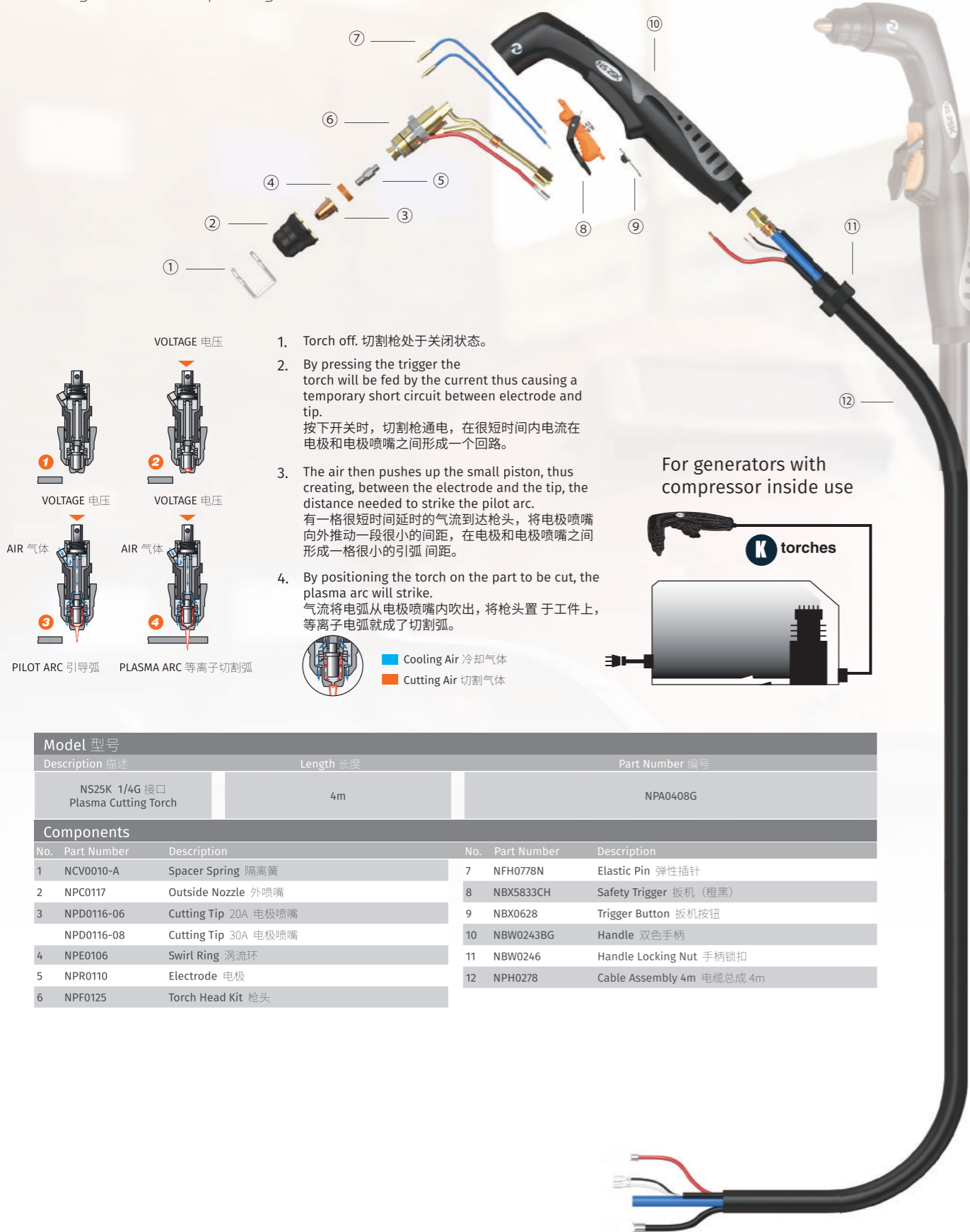

For generators with compressor inside use

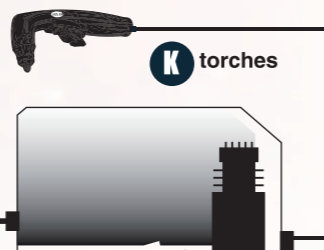

Model 型号		Description 描述		Length 长度	Part Number 编号
NS25K 1/4G 接口 Plasma Cutting Torch				4m	NPA0408G
Components					
No.	Part Number	Description	No.	Part Number	Description
1	NCV0010-A	Spacer Spring 隔离簧	7	NFH0778N	Elastic Pin 弹性插针
2	NPC0117	Outside Nozzle 外喷嘴	8	NBX5833CH	Safety Trigger 扳机 (橙黑)
3	NPD0116-06	Cutting Tip 20A 电极喷嘴	9	NBX0628	Trigger Button 扳机按钮
	NPD0116-08	Cutting Tip 30A 电极喷嘴	10	NBW0243BG	Handle 双色手柄
4	NPE0106	Swirl Ring 涡流环	11	NBW0246	Handle Locking Nut 手柄锁扣
5	NPR0110	Electrode 电极	12	NPH0278	Cable Assembly 4m 电缆总成 4m
	NPF0125	Torch Head Kit 枪头			

NS 25K WEAR PARTS

All our consumable parts are interchangeable with the original OEM specification
Production Materials sourced from qualified top tier supplier (s).

NO.	Part Number	Description	Φ(mm)	L(mm)	Contact Short	Contact Long	Drag Short	Drag Long	Gouging	Product picture
1	NCV0010-A	Spacer Spring		22.5	●					
	NCV0010N	Double Pointed Spacer	25	22	●					
	NCV0024	Buggy	23.5	33	●					
	NCV0007	Shield Cap				●				
2	NPC0117	Outside Nozzle		28	●	●				
	NPC0112	Shield Cap Body		26.2	●		●			
3	NPD0116-06	Cutting Tip 20A	0.65	17.3	●					
	NPD0116-08	Cutting Tip 30A	0.8	17.3	●					
	NPD0116-09	Cutting Tip 40A	0.9	17.3	●					
	NPD0103-65	Cutting Tip 20A	0.65	25.8	●					
	NPD0103-09	Cutting Tip 40A	0.9	25.8	●					
4	NPE0106	Swirl Ring			●					
5	NPR0110	Electrode		21.8	●					
	NPR0106	Electrode		30.5	●					

● Torch Package Standard Wear Part Set Up 包装标准配件
 Contact Short
 Contact Long
 Drag Short
 Drag Long
 Gouging

* Denotes Standard Build 表示标准配置，选配件须注明编号

NS 35K

额定值: 32A 35% 暂载率。切割厚度: 6-8mm。
Rating: 32A 35% duty. Cutting Thickness: 6-8mm.

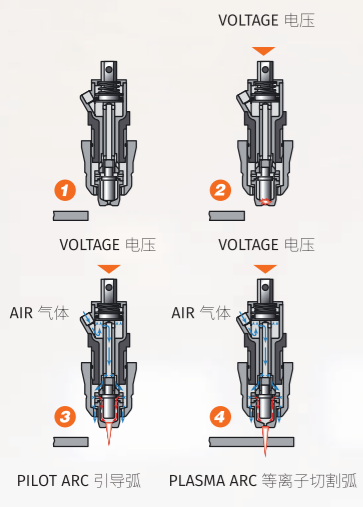
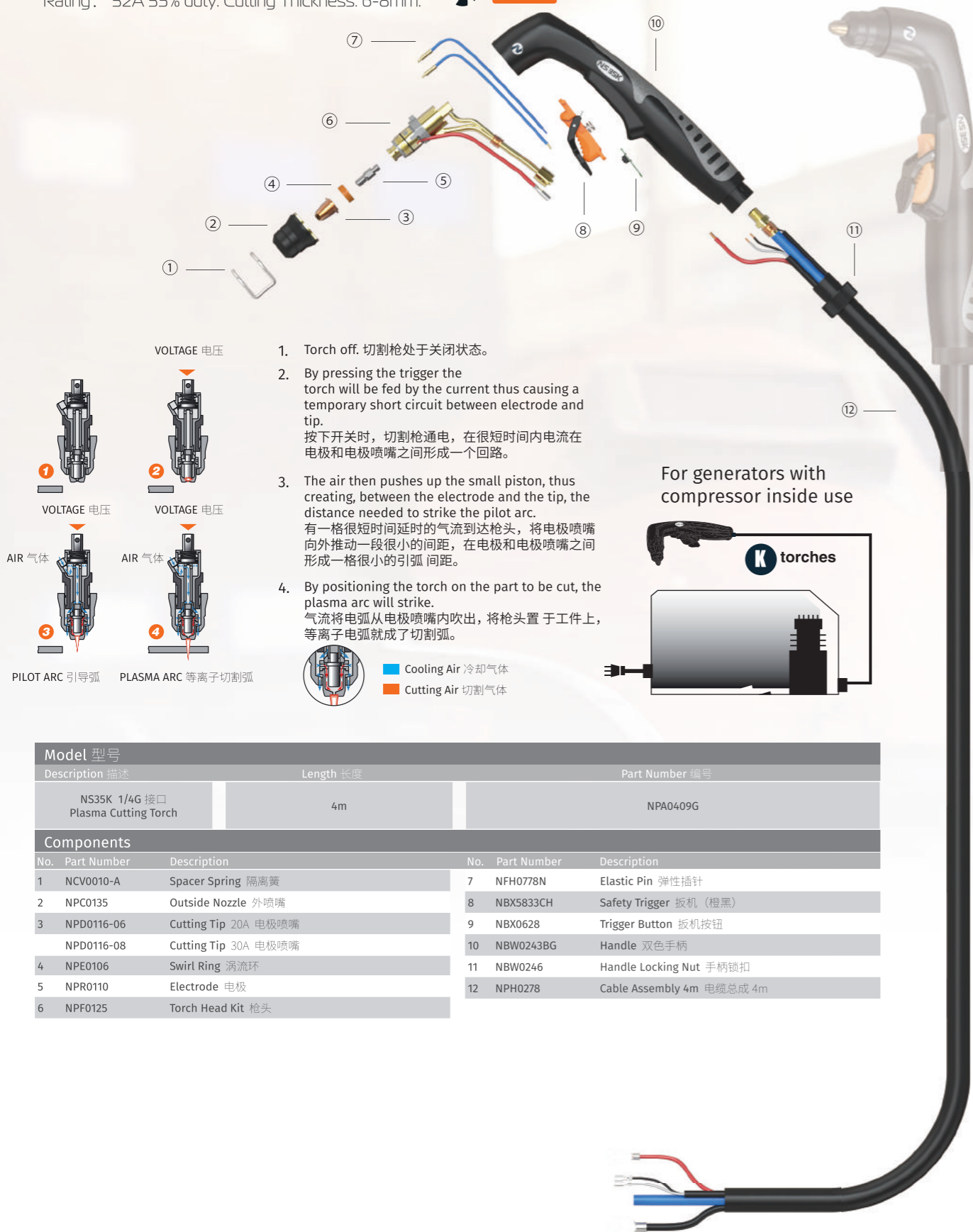

1. Torch off. 切割枪处于关闭状态。
2. By pressing the trigger the torch will be fed by the current thus causing a temporary short circuit between electrode and tip.
按下开关时, 切割枪通电, 在很短时间内电流在电极和电极喷嘴之间形成一个回路。
3. The air then pushes up the small piston, thus creating, between the electrode and the tip, the distance needed to strike the pilot arc.
有一格很短时间延时的气流到达枪头, 将电极喷嘴向外推动一段很小的间距, 在电极和电极喷嘴之间形成一格很小的引弧间距。
4. By positioning the torch on the part to be cut, the plasma arc will strike.
气流将电弧从电极喷嘴内吹出, 将枪头置于工件上, 等离子电弧就成了切割弧。

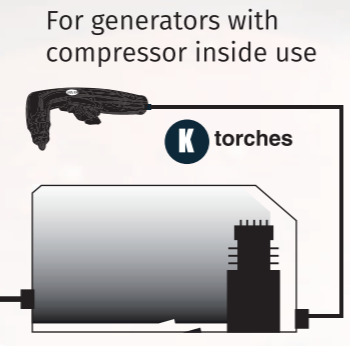

Model 型号		Description 描述		Length 长度	Part Number 编号
NS35K 1/4G 接口 Plasma Cutting Torch				4m	NPA0409G

Components			
No.	Part Number	Description	No. Part Number Description
1	NCV0010-A	Spacer Spring 隔离簧	7 NFH0778N Elastic Pin 弹性插针
2	NPC0135	Outside Nozzle 外喷嘴	8 NBX5833CH Safety Trigger 扳机 (橙黑)
3	NPD0116-06	Cutting Tip 20A 电极喷嘴	9 NBX0628 Trigger Button 扳机按钮
	NPD0116-08	Cutting Tip 30A 电极喷嘴	10 NBW0243BG Handle 双色手柄
4	NPE0106	Swirl Ring 涡流环	11 NBW0246 Handle Locking Nut 手柄锁扣
5	NPR0110	Electrode 电极	12 NPH0278 Cable Assembly 4m 电缆总成 4m
	NPF0125	Torch Head Kit 枪头	

NS 35K WEAR PARTS

All our consumable parts are interchangeable with the original OEM specification
Production Materials sourced from qualified top tier supplier (S).

NO.	Part Number	Description	Φ(mm)	L(mm)	Contact Short	Contact Long	Drag Short	Drag Long	Gouging	Product picture
1	NCV0010-A	Spacer Spring		22.5	●					
	NCV0010N	Double Pointed Spacer	25	22	●					
	NCV0024	Buggy	23.5	33	●					
	NCV0007	Shield Cap					●			
2	NPC0135	Outside Nozzle		28	●	●				
	NPC0107	Shield Cap Body		26.2	●	●	●			
3	NPD0116-06	Cutting Tip 20A	0.65	17.3	●					
	NPD0116-08	Cutting Tip 30A	0.8	17.3	●					
	NPD0116-09	Cutting Tip 40A	0.9	17.3	●					
	NPD0103-65	Cutting Tip 20A	0.65	25.8		●				
	NPD0103-09	Cutting Tip 40A	0.9	25.8		●				
4	NPE0106	Swirl Ring			●	●				
5	NPR0110	Electrode		21.8	●					
	NPR0106	Electrode		30.5		●				

● Torch Package Standard Wear Part Set Up 包装标准配件
 Contact Short
 Contact Long
 Drag Short
 Drag Long
 Gouging

* Denotes Standard Build 表示标准配置, 选配件须注明编号

NS 45

额定值：40A 60% 暂载率。切割厚度：8-12mm。
Rating: 40A 60% duty. Cutting Thickness: 8-12mm.

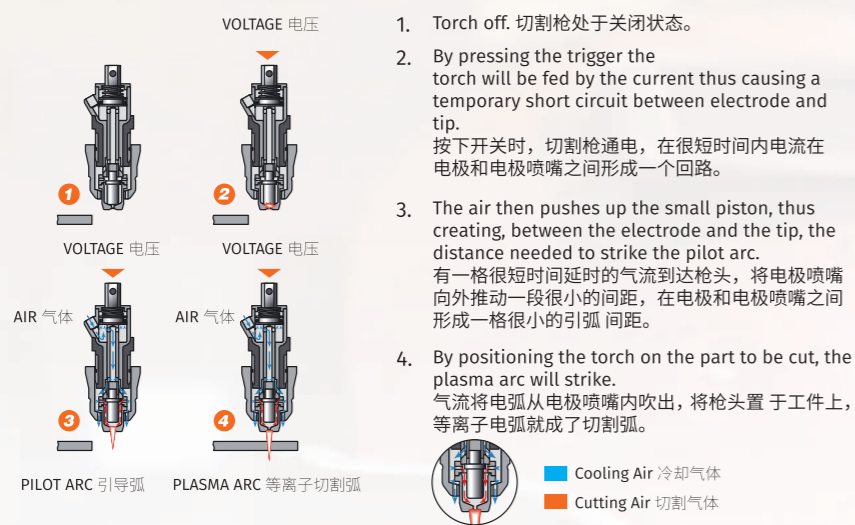

1. Torch off. 切割枪处于关闭状态。
2. By pressing the trigger the torch will be fed by the current thus causing a temporary short circuit between electrode and tip.
按下开关时，切割枪通电，在很短时间内电流在电极和电极喷嘴之间形成一个回路。
3. The air then pushes up the small piston, thus creating, between the electrode and the tip, the distance needed to strike the pilot arc.
有一格很短时间延时的气流到达枪头，将电极喷嘴向外推动一段很小的间距，在电极和电极喷嘴之间形成一格很小的引弧间距。
4. By positioning the torch on the part to be cut, the plasma arc will strike.
气流将电弧从电极喷嘴内吹出，将枪头置于工件上，等离子电弧就成了切割弧。

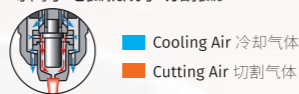

Model 型号	Description 描述	Length 长度	Part Number 编号
NS45 1/4G 接口 Plasma Cutting Torch		6m	NPA0165G
NS45 Adaptor 中央插头 Plasma Cutting Torch		6m	NPA0166G

No.	Part Number	Description	No.	Part Number	Description
1	NCV0010-A	Spacer Spring 隔离簧	8	NBX0628	Trigger Button 扳机按钮
2	NPC0116	Outside Nozzle 外喷嘴	9	NBW0243BG	Handle 双手柄
3	NPD0116-06	Cutting Tip 20A 电极喷嘴	10	NBW0246	Handle Locking Nut 手柄锁扣
	NPD0116-08	Cutting Tip 30A 电极喷嘴	11	NPH0295-4A	Cable Assembly 4m 4m 电缆总成
	NPD0116-09	Cutting Tip 40A 电极喷嘴	12	NCY0002	Back Cable Support 后尾护套
4	NPE0106	Swirl Ring 涡流环	13	NBW0195	Back Handle 后枪壳
5	NPR0110	Electrode 电极	14	NBW0174	Locking Nut 中央插头锁母
6	NPF0125	Torch Head Kit 枪头	15	NFY0018G	Central Connector 中央插头
7	NBX5833CH	Safety Trigger 扳机 (橙黑)			

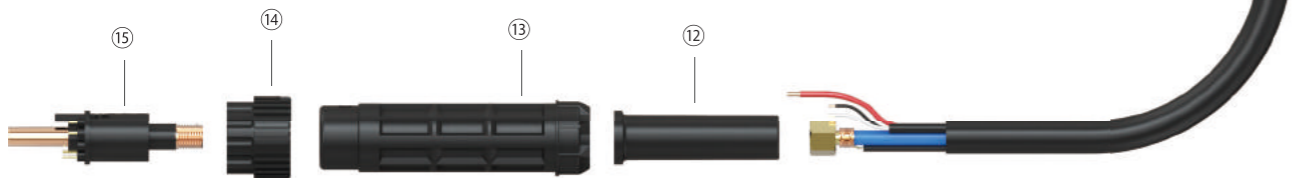

NS 45 WEAR PARTS

All our consumable parts are interchangeable with the original OEM specification
Production Materials sourced from qualified top tier supplier (s).

NO.	Part Number	Description	Φ(mm)	L(mm)	Contact Short	Contact Long	Drag Short	Drag Long	Gouging	Product picture
1	NCV0010-A	Spacer Spring		22.5	●					
	NCV0010N	Double Pointed Spacer	25	22	●					
	NCV0024	Buggy	23.5	33	●					
	NCV0007	Shield Cap					●			
2	NPC0116	Outside Nozzle		28	●	●				
	NPC0107	Shield Cap Body		26.2	●		●			
3	NPD0102-08	Cutting Tip 30A	0.8	13.3	●					
	NPD0102-10	Cutting Tip 50A	1.0	13.3	●					
	NPD0116-06	Cutting Tip 20A	0.65	17.3	●		●			
	NPD0116-08	Cutting Tip 30A	0.8	17.3	●		●			
	NPD0116-09	Cutting Tip 40A	0.9	17.3	●		●			
	NPD0103-65	Cutting Tip 20A	0.65	25.8			●			
4	NPD0103-09	Cutting Tip 40A	0.9	25.8			●			
	NPE0106	Swirl Ring			●	●				
5	NPR0105	Electrode		17.8	●					
	NPR0110	Electrode		21.8	●					
	NPR0106	Electrode		30.5	●					

● Torch Package Standard Wear Part Set Up 包装标准配件

* Denotes Standard Build 表示标准配置，选配件须注明编号

NS 65

额定值：60A 60% 暂载率。切割厚度：8-20mm。
Rating: 60A 60% duty. Cutting Thickness: 8-20mm.



NS 65 WEAR PARTS

All our consumable parts are interchangeable with the original OEM specification
Production Materials sourced from qualified top tier supplier (s).

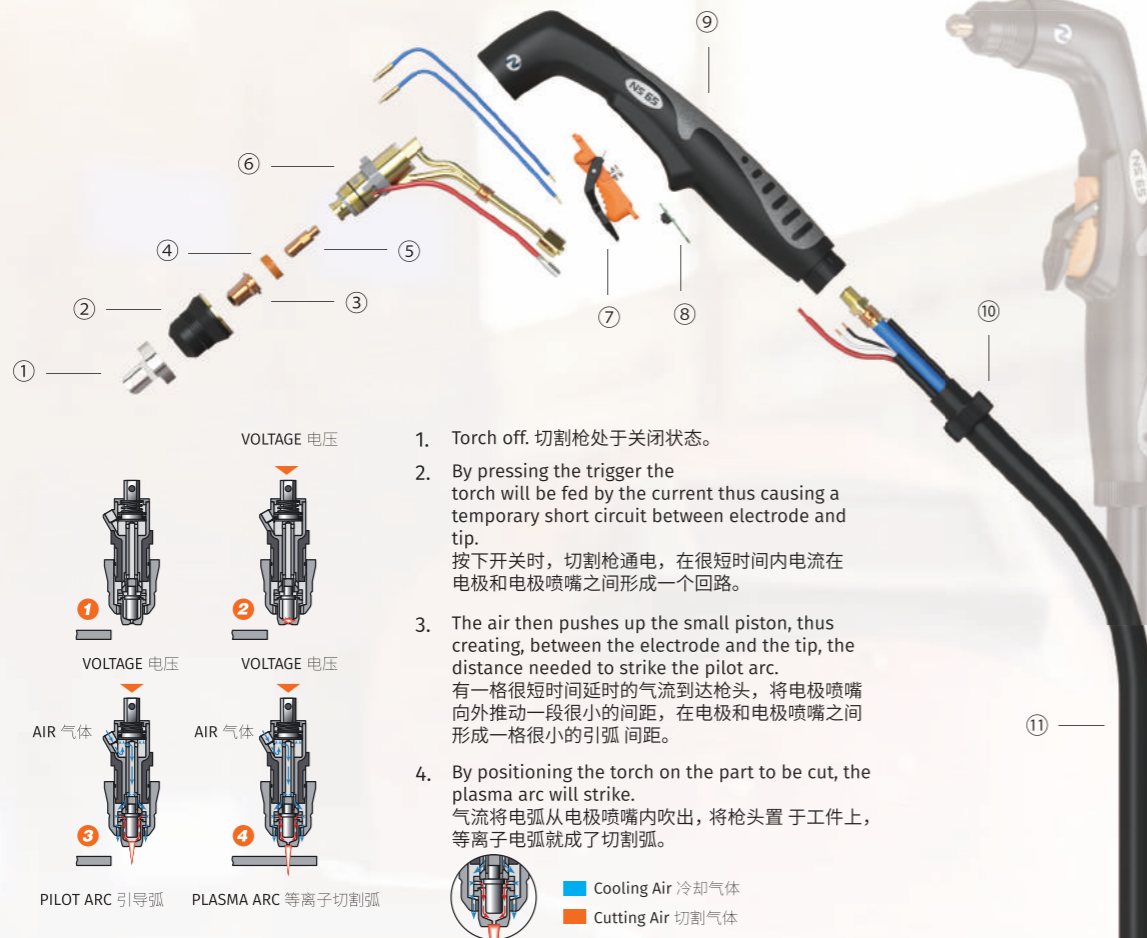

1. Torch off. 切割枪处于关闭状态。
2. By pressing the trigger the torch will be fed by the current thus causing a temporary short circuit between electrode and tip.
按下开关时，切割枪通电，在很短时间内电流在电极和电极喷嘴之间形成一个回路。
3. The air then pushes up the small piston, thus creating, between the electrode and the tip, the distance needed to strike the pilot arc.
有一格很短时间延时的气流到达枪头，将电极喷嘴向外推动一段很小的间距，在电极和电极喷嘴之间形成一格很小的引弧间距。
4. By positioning the torch on the part to be cut, the plasma arc will strike.
气流将电弧从电极喷嘴内吹出，将枪头置于工件上，等离子电弧就成了切割弧。

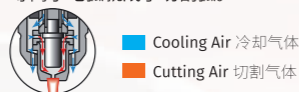
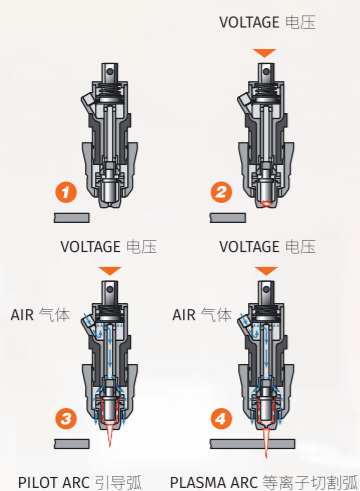

Model 型号	Description 描述	Length 长度	Part Number 编号
NS65 1/4G 接口 Plasma Cutting Torch		6m	NPA2201G
NS65 Adaptor 中央插头 Plasma Cutting Torch		6m	NPA2200G

Components					
No.	Part Number	Description	No.	Part Number	Description
1	NCV1118N	Double Pointed Spacer 隔离簧	9	NBW0243BG	Handle 双色手柄
2	NPC0098	Outside Nozzle 外喷嘴	10	NBW0246	Handle Locking Nut 手柄锁扣
3	NPD0098-08	Cutting Tip 40A 电极喷嘴	11	NPH0307	Cable Assembly 6m 电缆总成 6m
	NPD0098-10	Cutting Tip 60A 电极喷嘴	12	NCY0002	Back Cable Support 后尾护套
4	NPE0106	Swirl Ring 涡流环	13	NBW0195	Back Handle 后枪壳
5	NPR0098	Electrode 电极	14	NBW0174	Locking Nut 中央插头锁母
6	NPF0128	Torch Head Kit 枪头	15	NFY0018G	Central Connector 中央插头
7	NBX5833CH	Safety Trigger 扳机 (橙黑)			
8	NBX0628	Trigger Button 扳机按钮			

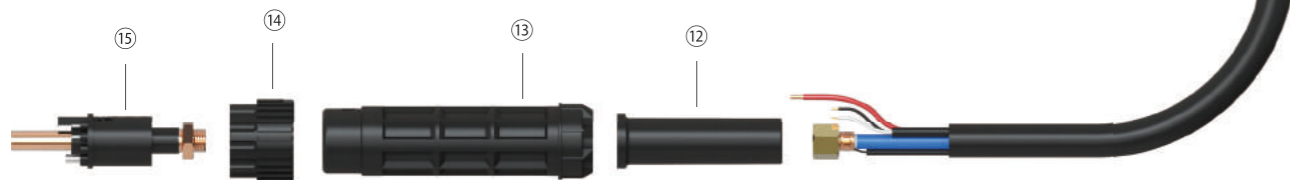

NO.	Part Number	Description	Φ(mm)	L(mm)						Product picture
					Contact Short	Contact Long	Drag Short	Drag Long	Gouging	
1	NCV1118N	Double Pointed Spacer	25	24.6	●					
	NCV0006	Shield Cap					●			
2	NPC0098	Outside Nozzle		28	●					
	NPC0110	Shield Cap Body		26.2	●		●			
3	NPD0098-08	Cutting Tip 40A	0.8	17.7	●		●			
	NPD0098-10	Cutting Tip 60A	1.0	17.7	●		●			
4	NPE0106	Swirl Ring			●					
5	NPR0098	Electrode		30.5	●					

● Torch Package Standard Wear Part Set Up 包装标准配件

● Contact Short

● Contact Long

● Drag Short

● Drag Long

● Gouging

* Denotes Standard Build 表示标准配置，选配件须注明编号

NS 75

额定值：70A 60%，50A 100% 暂载率。切割厚度：18-23mm。
Rating: 70A 60%, 50A 100% duty. Cutting Thickness: 18-23mm.



Model 型号	Description 描述	Length 长度	Part Number 编号
NS75 1/4G 接口 Plasma Cutting Torch		6m	NPA1606G
NS75 Adaptor 中央插头 Plasma Cutting Torch		6m	NPA1604G

Components					
No.	Part Number	Description	No.	Part Number	Description
1	NCV0028	Spacer Spring 隔离簧	9	NBX0496A	Elastic Pin 弹性插针
2	NCV0076	Ceramic Protective Cap 陶瓷保护帽	10	NBX5833CH	Safety Trigger 扳机 (橙黑)
3	NPC0114	Outside Nozzle 外喷嘴	11	NBX0628	Trigger Button 扳机按钮
4	NPD0114-10	Cutting Tip 50A 电极喷嘴	12	NBW0345BG	Handle 双色手柄
	NPD0114-12	Cutting Tip 70A 电极喷嘴	13	NBW0081	Handle Locking Nut 手柄锁紧护套
	NPD0118-10	Long Cutting Tip 50A 电极喷嘴	14	NPH8260	Cable Assembly 6m 电缆总成 6m
5	NPE0112	Swirl Ring 涡流环	15	NCY0002	Back Cable Support 后尾护套
6	NPR0117	Electrode 电极	16	NBW0195	Back Handle 后枪壳
	NPR0119	Long Electrode 长电极	17	NBW0174	Locking Nut 中央插头锁母
7	NFH0647	Cooling Tube 分流气嘴	18	NFY0018G	Central Connector 中央插头
8	NPF0135	Torch Head Kit 枪头			

NS 75 WEAR PARTS

All our consumable parts are interchangeable with the original OEM specification
 Production Materials sourced from qualified top tier supplier (s).

NO.	Part Number	Description	Φ(mm)	L(mm)	Contact Short	Contact Long	Drag Short	Drag Long	Gouging	Product picture
1	NCV0028	Spacer Spring		20.5	●					
	NCV0026	Double Pointed Spacer		25.5	●					
2	NCV0076	Ceramic Protective Cap			●					
	NPC0114	Outside Nozzle		39.5	●					
3	NPD0114-10	Cutting Tip 50A	1.0	18.6	●					
	NPD0114-12	Cutting Tip 70A	1.2	18.6	●					
	NPD0118-10	Cutting Tip 50A	1.0	31.1	●					
4	NPE0112	Swirl Ring			●	●				
5	NPR0117	Electrode		23.7	●					
	NPR0119	Electrode		36.2	●					
6	NFH0647	Cooling Tube			●	●				

● Torch Package Standard Wear Part Set Up 包装标准配件
 ● Contact Short
 ● Contact Long
 ● Drag Short
 ● Drag Long
 ● Gouging

* Denotes Standard Build 表示标准配置，选配件须注明编号

NS 80

额定值：80A 60%，60A 100% 暂载率。切割厚度：20-30mm。
Rating: 80A 60%, 60A 100% duty. Cutting Thickness: 20-30mm.



NS 80 WEAR PARTS

All our consumable parts are interchangeable with the original OEM specification
Production Materials sourced from qualified top tier supplier (s).



Model 型号	Description 描述	Length 长度	Part Number 编号
NS80 1/4G 接口 Plasma Cutting Torch		6m	NPA8606G
NS80 Adaptor 中央插头 Plasma Cutting Torch		6m	NPA8604G

Components			
No.	Part Number	Description	No. Part Number Description
1	NCV2055	Shield Cap 保护帽	9 NBX0496A Elastic Pin 弹性插针
2	NCV2054	Shield Cap Body 保护帽座	10 NBX5833CH Safety Trigger 扳机 (橙黑)
3	NPC0108	Outside Nozzle 外喷嘴	11 NBX0628 Trigger Button 扳机按钮
4	NPD0113-10	Cutting Tip 50A 电极喷嘴	12 NBW0345BG Handle 双色手柄
	NPD0113-12	Cutting Tip 70A 电极喷嘴	13 NBW0081 Handle Locking Nut 手柄锁紧护套
	NPD0113-14	Cutting Tip 80A 电极喷嘴	14 NPH8260 Cable Assembly 6m 电缆总成 6m
5	NPE0112	Swirl Ring 涡流环	15 NCV0002 Back Cable Support 后尾护套
6	NPR0113	Electrode 电极	16 NBW0195 Back Handle 后枪壳
7	NFH0647	Cooling Tube 分流气嘴	17 NBW0174 Locking Nut 中央插头锁母
8	NPF0135	Torch Head Kit 枪头	18 NPY0018G Central Connector 中央插头

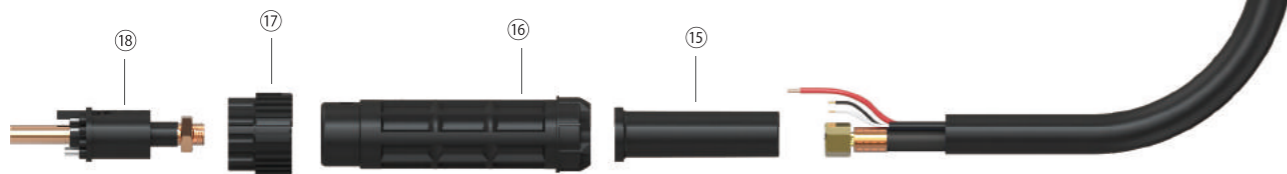

NO.	Part Number	Description	Φ(mm)	L(mm)	Contact Short	Contact Long	Drag Short	Drag Long	Gouging	Product picture
1	NCV2055	Shield Cap					●			
2	NCV2054	Shield Cap Body					●			
3	NPC0108	Outside Nozzle					●			
4	NPD0113-10	Cutting Tip 50A	1.0				●			
	NPD0113-12	Cutting Tip 70A	1.2				●			
	NPD0113-14	Cutting Tip 80A	1.4				●			
5	NPE0112	Swirl Ring					●			
6	NPR0113	Electrode					●			
7	NFH0647	Cooling Tube					●			

● Torch Package Standard Wear Part Set Up 包装标准配件
■ Contact Short ■ Contact Long ■ Drag Short ■ Drag Long ■ Gouging

* Denotes Standard Build 表示标准配置，选配件须注明编号

NS 105

额定值: 100A 60%, 70A 100% 暂载率。切割厚度: 25-30mm。
Rating: 100A 60%, 70A 100% duty. Cutting Thickness: 25-30mm.



1. Torch off. 切割枪处于关闭状态。
2. By pressing the trigger the torch will be fed by the current thus causing a temporary short circuit between electrode and tip.
按下开关时, 切割枪通电, 在很短时间内电流在电极和电极喷嘴之间形成一个回路。
3. The air then pushes up the small piston, thus creating, between the electrode and the tip, the distance needed to strike the pilot arc.
有一格很短时间延时的气流到达枪头, 将电极喷嘴向外推动一段很小的间距, 在电极和电极喷嘴之间形成一格很小的引弧间距。
4. By positioning the torch on the part to be cut, the plasma arc will strike.
气流将电弧从电极喷嘴内吹出, 将枪头置于工件上, 等离子电弧就成了切割弧。

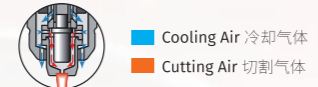

Model 型号	Description 描述	Length 长度	Part Number 编号
NS105 1/4G 接口 Plasma Cutting Torch		6m	NPA1654
NS105 Adaptor 中央插头 Plasma Cutting Torch		6m	NPA1652

Components					
No.	Part Number	Description	No.	Part Number	Description
1	NCV0011	Spacer Spring 隔离簧	10	NBX0628	Trigger Button 扳机按钮
2	NPC0118	Outside Nozzle 外喷嘴	11	NBW0345BG	Handle 双色手柄
3	NPD0119-10	Cutting Tip 50A 电极喷嘴	12	NBW0081	Handle Locking Nut 手柄锁紧护套
	NPD0119-12	Cutting Tip 70A 电极喷嘴	13	NPH8260	Cable Assembly 6m 电缆总成 6m
	NPD0119-14	Long Cutting Tip 100A 电极喷嘴	14	NCY0002	Back Cable Support 后尾护套
4	NPE0112	Swirl Ring 涡流环	15	NBW0195	Back Handle 后枪壳
5	NPR0117	Electrode 电极	16	NBW0174	Locking Nut 中央插头锁母
6	NFH0647	Cooling Tube 分流气嘴	17	NFY0018G	Central Connector 中央插头
7	NPF0136	Torch Head Kit 枪头			
8	NBX0496A	Elastic Pin 弹性插针			
9	NBX5833CH	Safety Trigger 扳机 (橙黑)			

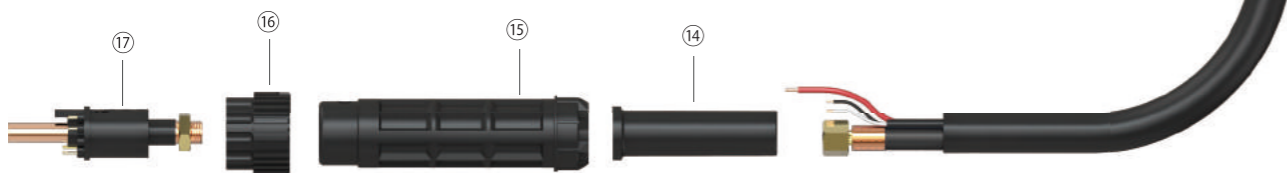

NS 105 WEAR PARTS

All our consumable parts are interchangeable with the original OEM specification
Production Materials sourced from qualified top tier supplier (s).

NO.	Part Number	Description	Φ(mm)	L(mm)	Contact Short	Contact Long	Drag Short	Drag Long	Gouging	Product picture
1	NCV0011	Spacer Spring		23	●					
	NCV0021	Buggy		40.6	●					
2	NPC0118	Outside Nozzle		39.5	●					
3	NPD0119-10	Cutting Tip 50A	1.0	18.7	●					
	NPD0119-12	Cutting Tip 70A	1.2	18.7	●					
	NPD0119-14	Cutting Tip 100A	1.4	18.7	●					
4	NPE0112	Swirl Ring			●		●			
5	NPR0117	Electrode		23.7	●					
6	NFH0647	Cooling Tube			●					



* Denotes Standard Build 表示标准配置, 选配件须注明编号

NS 125

额定值: 120A 60%, 90A 100% 暂载率。切割厚度: 10-35mm。
Rating: 120A 60%, 90A 100% duty. Cutting Thickness: 10-35mm.



Model 型号	Description 描述	Length 长度	Part Number 编号
NS125 1/4G 接口 Plasma Cutting Torch		6m	NPA2251
NS125 Adaptor 中央插头 Plasma Cutting Torch		6m	NPA2250

Components					
No.	Part Number	Description	No.	Part Number	Description
1	NCV0229	Double Pointed Spacer 隔离簧	9	NBX5833CH	Safety Trigger 扳机 (橙黑)
2	NPC0179	Outside Nozzle 外喷嘴	10	NBX0628	Trigger Button 扳机按钮
3	NPD0179-13	Cutting Tip 80A 电极喷嘴	11	NBW0345BG	Handle 双色手柄
	NPD0179-14	Cutting Tip 100A 电极喷嘴	12	NBW0081	Handle Locking Nut 手柄锁紧护套
	NPD0179-15	Long Cutting Tip 120A 电极喷嘴	13	NPH0450	Cable Assembly 6m 电缆总成 6m
4	NPE0179	Swirl Ring 涡流环	14	NCY0002	Back Cable Support 后尾护套
5	NPR0179	Electrode 电极	15	NBW0195	Back Handle 后枪壳
6	NFH0979	Cooling Tube 分流气嘴	16	NBW0174	Locking Nut 中央插头锁母
7	NPF0135	Torch Head Kit 枪头	17	NFY0018G	Central Connector 中央插头
8	NBX0496A	Elastic Pin 弹性插针			

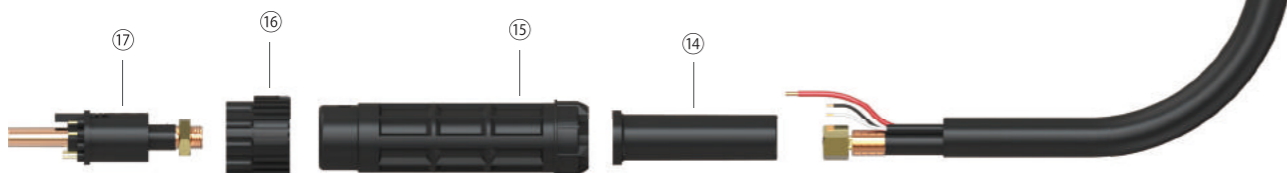

NS 125 WEAR PARTS

All our consumable parts are interchangeable with the original OEM specification
Production Materials sourced from qualified top tier supplier (s).

NO.	Part Number	Description	Φ(mm)	L(mm)					Product picture	
					Contact Short	Contact Long	Drag Short	Drag Long		Gouging
1	NCV0229	Double Pointed Spacer		35.2	●					
2	NPC0179	Outside Nozzle		39.5	●					
3	NPD0179-13	Cutting Tip 80A	1.3	20	●					
	NPD0179-14	Cutting Tip 100A	1.4	20	●					
	NPD0179-15	Cutting Tip 120A	1.5	20	●					
4	NPE0179	Swirl Ring		12.6	●					
5	NPR0179	Electrode		24.6	●					
6	NFH0979	Cooling Tube			●					

● Torch Package Standard Wear Part Set Up 包装标准配件
 Contact Short
 Contact Long
 Drag Short
 Drag Long
 Gouging

* Denotes Standard Build 表示标准配置, 选配件请注明编号

NA Range



CNC 精密加工及高质量工程材料。
CNC machined consumables part and aerospace polymers.



人机工学设计，实用、耐用型枪壳。
Ergonomic, solid handle design.



增加安全防护板，避免意外发生。
A mechanical lever fitted to the trigger for user safety.



可适配多种后尾接头。
Terminations are offered in a "direct to machine" or central connector configuration.

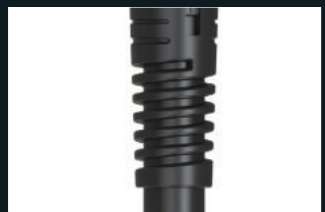

灵活的支撑设计。
Spiral design helps support the cable and offer great all day comfort use.

NA 81

额定值：80A 60%，60A 100% 暂载率。切割厚度：20-25mm。
Rating: 80A 60%, 60A 100% duty. Cutting Thickness: 20-25mm.



Model 型号	Description 描述	Length 长度	Part Number 编号
NA81 1/4G 接口 Plasma Cutting Torch		6m	NPA1404
NA81 Adaptor 中央插头 Plasma Cutting Torch		6m	NPA1402

Components					
No.	Part Number	Description	No.	Part Number	Description
1	NCV0028	Spacer Spring 隔离簧	11	NBW0345BG	Handle 双色手柄
2	NPC0115	Outside Nozzle 外喷嘴	12	NBW0081	Handle Locking Nut 手柄锁紧护套
3	NPD0105-10	Cutting Tip 50A 电极喷嘴	13	NPH1260	Cable Assembly 6m 电缆总成 6m
	NPD0105-12	Cutting Tip 80A 电极喷嘴	14	NCY0002	Back Cable Support 后尾护套
4	NPE0107	Swirl Ring 涡流环	15	NBW0195	Back Handle 后枪壳
5	NPR0109	Electrode 电极	16	NBW0174	Locking Nut 中央插头锁母
6	NFH0560	Cooling Tubes 分流气嘴	17	NFY0018G	Central Connector 中央插头
7	NPF0140	Torch Head Kit 枪头			
8	NBX0496A	Elastic Pin 弹性插针			
9	NBX5833CH	Safety Trigger 扳机 (橙黑)			
10	NBX0628	Trigger Button 扳机按钮			

Technical Data 参数	NA 81	NA 101	NA 141	NA 151
Cooling Method: 冷却方式	Air-Cooled	Air-Cooled	Air-Cooled	Air-Cooled
Rating: 额定电流	80A 60A	100A 75A	140A 100A	150A 120A
Duty Cycle: 暂载率	60% 100%	60% 100%	60% 100%	60% 100%
Cutting Thickness: 切割厚度	20-25mm	25-30mm	35-40mm	35-40mm

High Frequency 高频等离子割枪

Order Part No.	1/4G	4M			
		5M			
CENTRAL ADAPTOR	6M	NPA1404	NPA1454	NPA1502	NPA1552
		4M			
		5M			
	6M	NPA1402	NPA1452	NPA1504	NPA1554

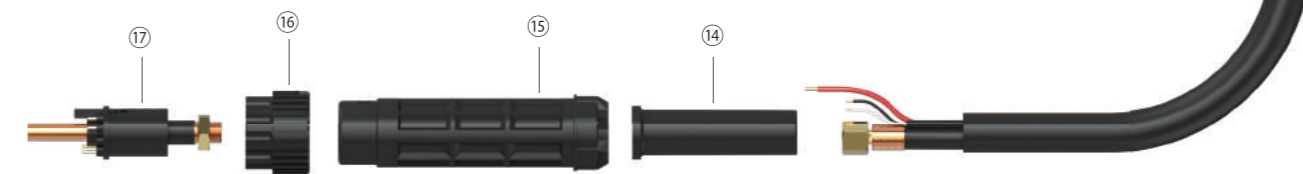

* Denotes Standard Build 表示标准配置，选配件须注明编号

NA 81 WEAR PARTS

All our consumable parts are interchangeable with the original OEM specification
Production Materials sourced from qualified top tier supplier (S).

NO.	Part Number	Description	Φ(mm)	L(mm)						Product picture
					Contact Short	Contact Long	Drag Short	Drag Long	Gouging	
1	NCV0026	Double Pointed Spacer		25.5	●					
	NCV0028	Spacer Spring		20.5	●					
	NCV0033	Spacer Crown		26	●					
	NCV0051	Buggy		31	●					
	NCV0201	Stand Off Guide		30		●				
2	NPC0115	Outside Nozzle		35.4	●	●				
3	NPD0105-10	Cutting Tip 50A	1.0	13.3	●					
	NPD0105-12	Cutting Tip 80A	1.2	13.3	●					
4	NPE0107	Swirl Ring			●	●				
5	NPR0109	Electrode		27	●					
6	NFH0560	Cooling Tube			●					

● Torch Package Standard Wear Part Set Up 包装标准配件
 Contact Short
 Contact Long
 Drag Short
 Drag Long
 Gouging

NA 101

额定值：100A 60%，75A 100% 暂载率。切割厚度：25-30mm。
Rating: 100A 60%, 75A 100% duty. Cutting Thickness: 25-30mm.

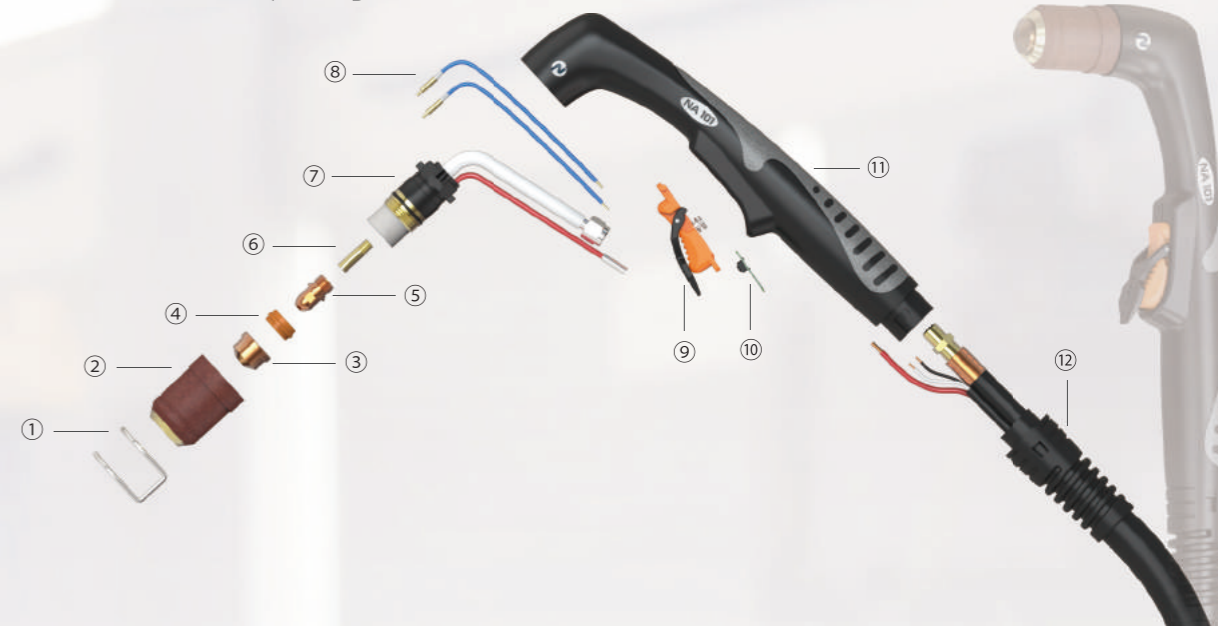

Model 型号	Description 描述	Length 长度	Part Number 编号
NA101 1/4G 接口 Plasma Cutting Torch		6m	NPA1454
NA101 Adaptor 中央插头 Plasma Cutting Torch		6m	NPA1452

Components					
No.	Part Number	Description	No.	Part Number	Description
1	NCV0011	Spacer Spring 隔离簧	9	NBX5833CH	Safety Trigger 扳机 (橙黑)
2	NPC0111	Outside Nozzle 外喷嘴	10	NBX0628	Trigger Button 扳机按钮
3	NPD0101-11	Cutting Tip 60A 电极喷嘴	11	NBW0345BG	Handle 双色手柄
	NPD0101-14	Cutting Tip 100A 电极喷嘴	12	NBW0081	Handle Locking Nut 手柄锁紧护套
	NPD0101-17	Cutting Tip 130A 电极喷嘴	13	NPH0143	Cable Assembly 6m 电缆总成 6m
	NPD0101-19	Cutting Tip 140A 电极喷嘴	14	NCY0002	Back Cable Support 后枪壳
4	NPE0101	Swirl Ring 涡流环	15	NBW0195	Back Handle 后枪壳
5	NPR0101	Electrode 电极	16	NBW0174	Locking Nut 中央插头锁母
6	NFH0562	Cooling Tubes 分流气嘴	17	NFY0018G	Central Connector 中央插头
7	NPF0145	Torch Head Kit 枪头			
8	NBX0496A	Elastic Pin 弹性插针			

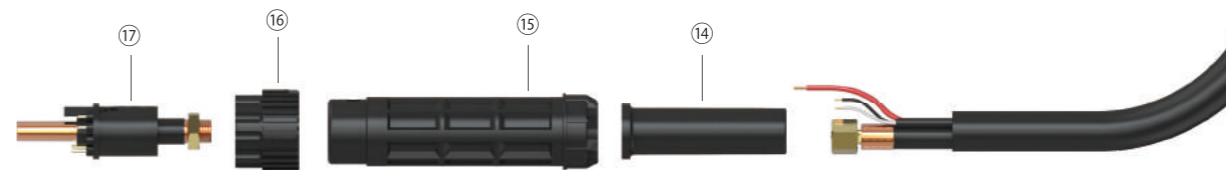

* Denotes Standard Build 表示标准配置，选配件须注明编号

NA 101 WEAR PARTS

All our consumable parts are interchangeable with the original OEM specification
Production Materials sourced from qualified top tier supplier (S).

NO.	Part Number	Description	Φ(mm)	L(mm)	Contact Short	Contact Long	Drag Short	Drag Long	Gouging	Product picture
1	NCV0008	Shield Cap		32.5		●				
	NCV0009	Shield Cap		38.6				●		
	NCV0011	Spacer Spring		23	●					
	NCV0012	Double Pointed Spacer		30		●				
	NCV0014	Spacer Crown		30				●		
	NCV0021	Buggy	32.8	40.6					●	
	NCV0023	Shield Cap		17.6					●	
	NCV0039	Shield Cap		18.5					●	
2	FH0297	For NCV0039/NCV0023							●	
	NPC0111	Outside Nozzle		44.1	●					
	NPC0113	Shield Cap Body		42.3		●				
	NPC0130	Shield Cap Body		42.9					●	
3	NPD0101-08	Cutting Tip 30A	0.8	13.7						
	NPD0101-11	Cutting Tip 60A	1.1	13.7						
	NPD0101-14	Cutting Tip 100A	1.4	13.7	●					
	NPD0101-17	Cutting Tip 130A	1.7	13.7						
	NPD0101-19	Cutting Tip 140A	1.9	13.7						
	NPD0101-30	Gouging	3.0	13.7					●	
	NPD0117-14	Cutting Tip 100A	1.4	34.8					●	
	NPD0117-17	Cutting Tip 130A	1.7	34.8					●	
	NPD0117-19	Cutting Tip 140A	1.9	34.8					●	
	NPD0117-19	Cutting Tip 140A	1.9	34.8					●	
4	NPE0101	Swirl Ring			●					
	NPE0103	Swirl Ring				●				
5	NPR0101	Electrode		22	●					
	NPR0116	Electrode		43.1						
6	NFH0562	Cooling Tube			●					

● Torch Package Standard Wear Part Set Up 包装标准配件

■ Contact Short ■ Contact Long ■ Drag Short ■ Drag Long ■ Gouging

NA 141

额定值：140A 60%，100A 100% 暂载率。切割厚度：35-40mm。
Rating: 140A 60%, 100A 100% duty. Cutting Thickness: 35-40mm.

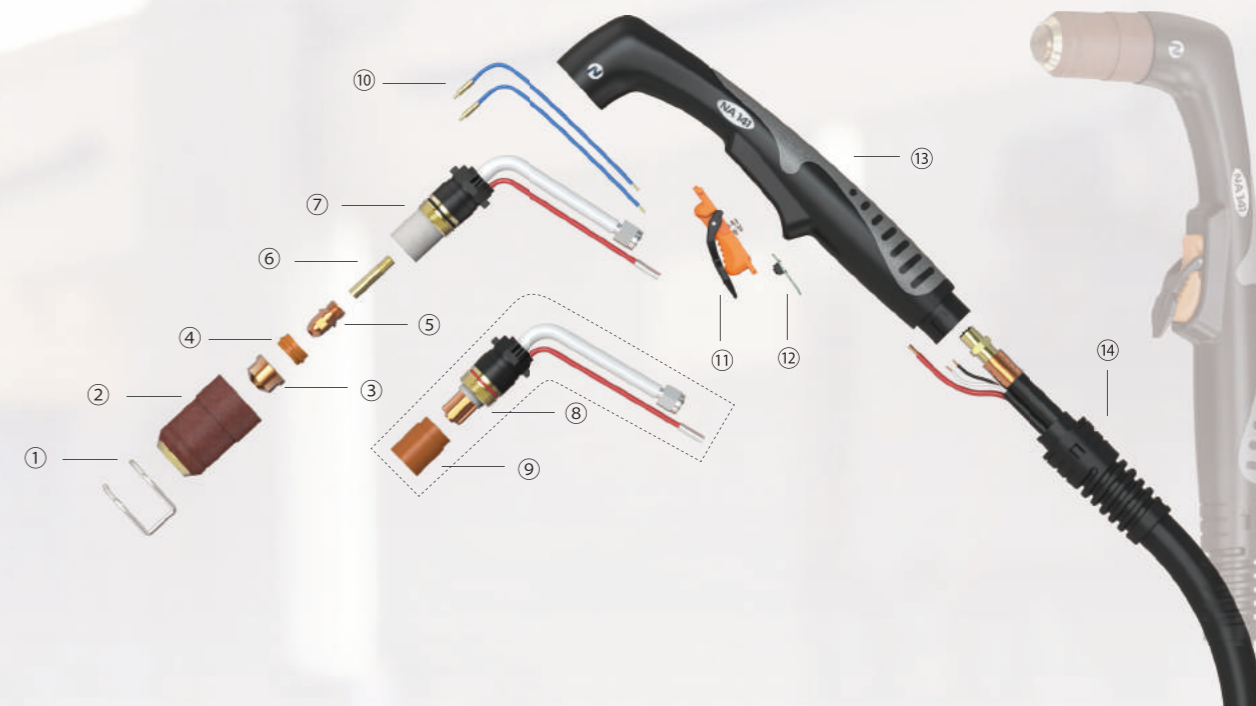

Model 型号	Description 描述	Length 长度	Part Number 编号
NA141 1/4G 接口 Plasma Cutting Torch		6m	NPA1502
NA141 Adaptor 中央插头 Plasma Cutting Torch		6m	NPA1504

Components					
No.	Part Number	Description	No.	Part Number	Description
1	NCV0011	Spacer Spring 隔离簧	10	NBX0496A	Elastic Pin 弹性插针
2	NPC0102	Outside Nozzle 外喷嘴	11	NBX5833CH	Safety Trigger 扳机 (橙黑)
3	NPD0101-11	Cutting Tip 60A 电极喷嘴	12	NBX0628	Trigger Button 扳机按钮
	NPD0101-14	Cutting Tip 100A 电极喷嘴	13	NBW0345BG	Handle 双色手柄
	NPD0101-17	Cutting Tip 130A 电极喷嘴	14	NBW0081	Handle Locking Nut 手柄锁紧护套
	NPD0101-19	Cutting Tip 140A 电极喷嘴	15	NPH1171	Cable Assembly 6m 电缆总成 6m
4	NPE0101	Swirl Ring 涡流环	16	NCY0002	Back Cable Support 后尾护套
5	NPR0101	Electrode 电极	17	NBW0195	Back Handle 后枪壳
6	NFH0563	Cooling Tubes 分流气嘴	18	NBW0174	Locking Nut 中央插头锁母
7	NPF0155	Torch Head Kit 枪头	19	NFY0018G	Central Connector 中央插头
8	NPF0156	Removable Torch Head Kit 可拆枪头			
9	NFH0619	Removable Insulator 可拆卸绝缘体			

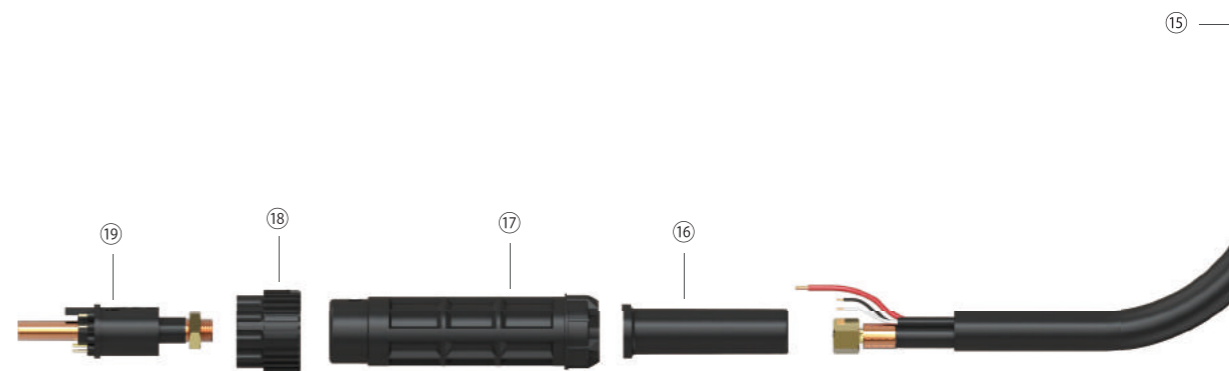

* Denotes Standard Build 表示标准配置，选配件须注明编号

NA 141 WEAR PARTS

All our consumable parts are interchangeable with the original OEM specification
Production Materials sourced from qualified top tier supplier (s).

NO.	Part Number	Description	Φ(mm)	L(mm)	Contact Short	Contact Long	Drag Short	Drag Long	Gouging	Product picture
1	NCV0008	Shield Cap		32.5		●				
	NCV0009	Shield Cap		38.6				●		
	NCV0011	Spacer Spring		23	●					
	NCV0012	Double Pointed Spacer		30	●					
	NCV0013	Stand Off Guide		33					●	
	NCV0014	Spacer Crown		30	●					
	NCV0021	Buggy	32.8	40.6	●					
	NCV0023	Shield Cap		17.6					●	
	NCV0039	Shield Cap		18.5		●				
2	FH0297	For NCV0039/NCV0023								
	NPC0102	Outside Nozzle		52.1	●					
	NPC0103	Outside Nozzle		50.3		●				
	NPC0131	Outside Nozzle		50.9	●	●	●	●		
3	NPD0101-08	Cutting Tip 30A	0.8	13.7						
	NPD0101-11	Cutting Tip 60A	1.1	13.7						
	NPD0101-14	Cutting Tip 100A	1.4	13.7						
	NPD0101-17	Cutting Tip 130A	1.7	13.7	●					
	NPD0101-19	Cutting Tip 140A	1.9	13.7						
	NPD0101-30	Gouging	3.0	13.7					●	
	NPD0117-14	Cutting Tip 100A	1.4	34.8				●		
	NPD0117-17	Cutting Tip 130A	1.7	34.8				●		
	NPD0117-19	Cutting Tip 140A	1.9	34.8				●		
4	NPE0101	Swirl Ring			●					
	NPE0103	Swirl Ring				●		●		
5	NPR0101	Electrode		12.6	●					
	NPR0103	Electrode		24.6				●		
6	NFH0563	Cooling Tube			●					

● Torch Package Standard Wear Part Set Up 包装标准配件
 Contact Short
 Contact Long
 Drag Short
 Drag Long
 Gouging

NA 151

额定值：150A 60%，120A 100% 暂载率。切割厚度：35-40mm。
Rating: 150A 60%, 120A 100% duty. Cutting Thickness: 35-40mm.

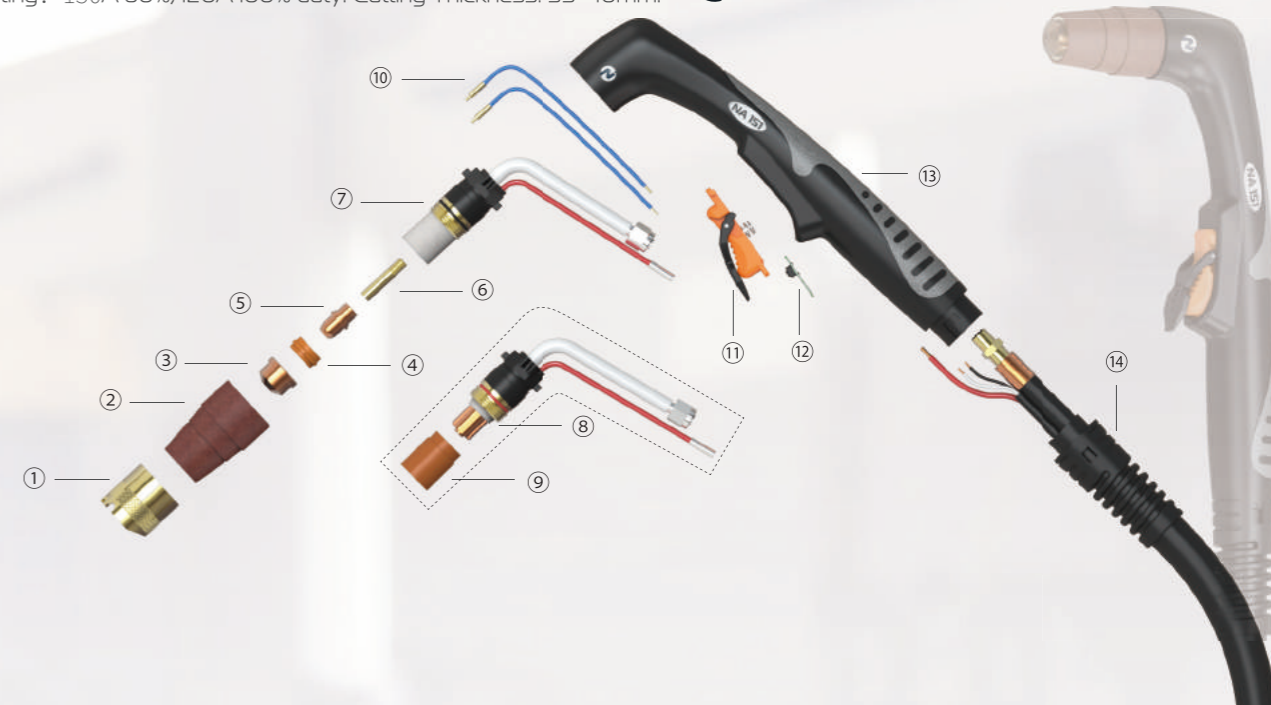

Model 型号	Description 描述	Length 长度	Part Number 编号
NA151 1/4G 接口 Plasma Cutting Torch		6m	NPA1552
NA151 Adaptor 中央插头 Plasma Cutting Torch		6m	NPA1554

Components					
No.	Part Number	Description	No.	Part Number	Description
1	NCV1105	Stand Off Guide 隔离簧	10	NBX0496A	Elastic Pin 弹性插针
2	NPC0120	Outside Nozzle 外喷嘴	11	NBX5833CH	Safety Trigger 扳机 (橙黑)
3	NPD0109-11	Cutting Tip 60A 电极喷嘴	12	NBX0628	Trigger Button 扳机按钮
	NPD0109-14	Cutting Tip 100A 电极喷嘴	13	NBW0345BG	Handle 双色手柄
	NPD0109-16	Cutting Tip 130A 电极喷嘴	14	NBW0081	Handle Locking Nut 手柄锁紧护套
	NPD0109-18	Cutting Tip 150A 电极喷嘴	15	NPH1171	Cable Assembly 6m 电缆总成 6m
4	NPE0103	Swirl Ring 涡流环	16	NCY0002	Back Cable Support 后尾护套
5	NPR0111	Electrode 电极	17	NBW0195	Back Handle 后枪壳
6	NFH0563	Cooling Tubes 分流气嘴	18	NBW0174	Locking Nut 中央插头锁母
7	NPF0160	Torch Head Kit 枪头	19	NFY0018G	Central Connector 中央插头
8	NPF0156	Removable Torch Head Kit 可拆枪头			
9	NFH0619	Removable Insulator 可拆卸绝缘体			

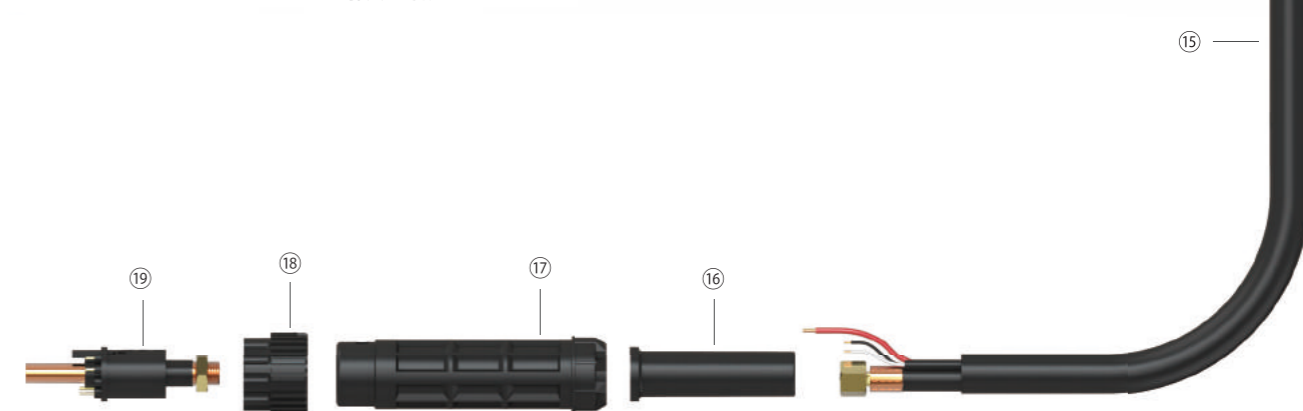

* Denotes Standard Build 表示标准配置，选配件须注明编号

NA 151 WEAR PARTS

All our consumable parts are interchangeable with the original OEM specification
Production Materials sourced from qualified top tier supplier (s).

NO.	Part Number	Description	Φ(mm)	L(mm)	Contact Short	Contact Long	Drag Short	Drag Long	Gouging	Product picture
1	NCV0008	Shield Cap		32.5		●				
	NCV0009	Shield Cap		38.6				●		
	NCV0011	Spacer Spring		23	●					
	NCV0012	Double Pointed Spacer		30	●					
	NCV0014	Spacer Crown		30	●					
	NCV0021	Buggy	32.8	40.6	●					
	NCV0023	Shield Cap		17.6					●	
	NCV0039	Shield Cap		18.5	●					
	NCV1105	Stand Off Guide		30	●					
	NCV1106	Stand Off Guide		28	●					
	NCV1107	Stand Off Guide		17	●					
2	NBW0139				●					
	NBW0146				●					
	FH0297	For NCV0039/NCV0023			●					
3	NPC0120	Outside Nozzle		50.9	●	●				
	NPC0131	Shield Cap Body		50.9	●	●		●		
	NPD0109-11	Cutting Tip 60A	1.1	12.7	●					
	NPD0109-14	Cutting Tip 100A	1.4	12.7	●					
	NPD0109-16	Cutting Tip 130A		12.7	●					
	NPD0109-18	Cutting Tip 150A	1.8	12.7	●					
	NPD0109-30	Gouging	3.0	12.7					●	
	NPD0117-14	Cutting Tip 100A	1.4	34.8				●		
4	NPD0117-17	Cutting Tip 130A	1.7	34.8				●		
	NPD0117-19	Cutting Tip 140A	1.9	34.8				●		
	NPE0103	Swirl Ring			●	●		●	●	
5	NPR0111	Electrode		20.5	●					
	NPR0116	Electrode		43.1		●		●		
6	NFH0563	Cooling Tube			●	●	●	●		

● Torch Package Standard Wear Part Set Up 包装标准配件

■ Contact Short ■ Contact Long ■ Drag Short ■ Drag Long ■ Gouging

CB Range



CNC 精密加工及高质量工程材料。
CNC machined consumables part and aerospace polymers.



人机工学设计，实用、耐用型枪壳。
Ergonomic, solid handle design.



增加安全防护板，避免意外发生。
A mechanical lever fitted to the trigger for user safety.



可适配多种后尾接头。
Terminations are offered in a "direct to machine" or central connector configuration.

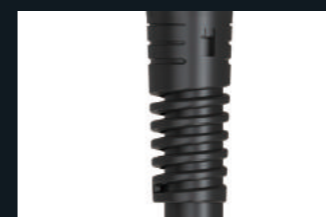

灵活的支撑设计。
Spiral design helps support the cable and offer great all day comfort use.



Technical Data 参数	CB 50	CB 70	CB 100	CB 150
Cooling Method: 冷却方式	Air-Cooled	Air-Cooled	Air-Cooled	Air-Cooled
Rating: 额定电流	50A 40A	70A 50A	100A 70A	150A 110A
Duty Cycle: 暂载率	60% 100%	60% 100%	60% 100%	60% 100%
Cutting Thickness: 切割厚度	10-15mm	18-24mm	24-30mm	35-40mm

High Frequency 高频等离子割枪

Order Part No.	1/4G	4M			
		5M			
CENTRAL ADAPTOR	6M	NPA1301G	NPA1323G	NPA1351	NPA1371
		4M			
		5M			
	6M	NPA1302G	NPA1322G	NPA1352	NPA1372

CB 50

额定值：50A 60%，40A 100% 暂载率。切割厚度：10-15mm。
Rating: 50A 60%, 40A 100% duty. Cutting Thickness: 10-15mm.



Model 型号		
Description 描述	Length 长度	Part Number 编号
CB50 1/4G 接口 Plasma Cutting Torch	6m	NPA1301G
CB50 Adaptor 中央插头 Plasma Cutting Torch	6m	NPA1302G

Components			
No.	Part Number	Description	No. Part Number Description
1	NPC0003	Outside Nozzle 外喷嘴	9 NBW0243BG Handle 双色手柄
2	NPD0015-10	Cutting Tip 50A 电极喷嘴	10 NBW0246 Handle Locking Nut 手柄锁扣
	NPD0088-11	Cutting Tip 60A 电极喷嘴	11 NPH81245YT Cable Assembly 6m 电缆总成 6m
3	NPE0007	Swirl Ring 涡流环	12 NCY0002 Back Cable Support 后尾护套
4	NPR0017	Electrode 电极	13 NBW0195 Back Handle 后枪壳
5	NPF0050	Torch Head Kit 枪头	14 NBW0174 Locking Nut 中央插头锁母
6	NFH0778N	Elastic Pin 弹性插针	15 NFY0018G Central Connector 中央插头
7	NBX5833CH	Safety Trigger 扳机 (橙黑)	
8	NBX0628	Trigger Button 扳机按钮	

CB 50 WEAR PARTS

All our consumable parts are interchangeable with the original OEM specification
Production Materials sourced from qualified top tier supplier (s).

NO.	Part Number	Description	Φ(mm)	L(mm)						Product picture
					Contact Short	Contact Long	Drag Short	Drag Long	Gouging	
1	NCV0037	Buggy	24.3	31	●					
2	NPC0003	Outside Nozzle		35.6	●	●				
3	NPD0014-10	Cutting Tip 50A	1.0	26.1		●				
	NPD0015-10	Cutting Tip 50A	1.0	11.2	●					
	NPD0015-12	Cutting Tip 60A	1.2	11.2		●				
	NPD0019-08	Cutting Tip 40A	0.8	11.6		●				
	NPD0019-10	Cutting Tip 50A	1.0	11.6		●				
	NPD0019-12	Cutting Tip 60A	1.2	11.6		●				
	NPD0085-98	Cutting Tip 50A	0.98	26.2		●				
	NPD0088-06	Cutting Tip 20A	0.65	12.3		●				
	NPD0088-08	Cutting Tip 40A	0.8	12.3		●				
	NPD0088-10	Cutting Tip 50A	1.0	12.3		●				
	NPD0088-11	Cutting Tip 60A	1.1	12.3		●				
	NPD0088-12	Cutting Tip 70A	1.2	12.3		●				
4	NPE0007	Swirl Ring			●	●				
5	NPR0017	Electrode		17.3	●					
	NPR0065	Electrode		32.5		●				

● Torch Package Standard Wear Part Set Up 包装标准配件
 Contact Short
 Contact Long
 Drag Short
 Drag Long
 Gouging

* Denotes Standard Build 表示标准配置，选配件须注明编号

CB 50

额定值：50A 60%，40A 100% 暂载率。切割厚度：10-15mm。
Rating: 50A 60%, 40A 100% duty. Cutting Thickness: 10-15mm.



Model 型号		
Description 描述	Length 长度	Part Number 编号
CB50 1/4G 接口 Plasma Cutting Torch	6m	NPA1301G
CB50 Adaptor 中央插头 Plasma Cutting Torch	6m	NPA1302G

Components			
No.	Part Number	Description	No. Part Number Description
1	NPC0003	Outside Nozzle 外喷嘴	9 NBW0243BG Handle 双色手柄
2	NPD0015-10	Cutting Tip 50A 电极喷嘴	10 NBW0246 Handle Locking Nut 手柄锁扣
	NPD0088-11	Cutting Tip 60A 电极喷嘴	11 NPH81245YT Cable Assembly 6m 电缆总成 6m
3	NPE0007	Swirl Ring 涡流环	12 NCY0002 Back Cable Support 后尾护套
4	NPR0017	Electrode 电极	13 NBW0195 Back Handle 后枪壳
5	NPF0050	Torch Head Kit 枪头	14 NBW0174 Locking Nut 中央插头锁母
6	NFH0778N	Elastic Pin 弹性插针	15 NPY0018G Central Connector 中央插头
7	NBX5833CH	Safety Trigger 扳机 (橙黑)	
8	NBX0628	Trigger Button 扳机按钮	

CB 50 WEAR PARTS

All our consumable parts are interchangeable with the original OEM specification
Production Materials sourced from qualified top tier supplier (s).

NO.	Part Number	Description	Φ(mm)	L(mm)						Product picture	
					Contact Short	Contact Long	Drag Short	Drag Long	Gouging		
1	NCV0037	Buggy	24.3	31	●						
2	NPC0003	Outside Nozzle		35.6	●	●					
3	NPD0014-10	Cutting Tip 50A	1.0	26.1		●					
	NPD0015-10	Cutting Tip 50A	1.0	11.2	●						
	NPD0015-12	Cutting Tip 60A	1.2	11.2		●					
	NPD0019-08	Cutting Tip 40A	0.8	11.6		●					
	NPD0019-10	Cutting Tip 50A	1.0	11.6		●					
	NPD0019-12	Cutting Tip 60A	1.2	11.6		●					
	NPD0085-98	Cutting Tip 50A	0.98	26.2		●					
	NPD0088-06	Cutting Tip 20A	0.65	12.3		●					
	NPD0088-08	Cutting Tip 40A	0.8	12.3		●					
	NPD0088-10	Cutting Tip 50A	1.0	12.3		●					
	NPD0088-11	Cutting Tip 60A	1.1	12.3		●					
	NPD0088-12	Cutting Tip 70A	1.2	12.3		●					
4	NPE0007	Swirl Ring			●	●					
5	NPR0017	Electrode		17.3	●						
	NPR0065	Electrode		32.5		●					

● Torch Package Standard Wear Part Set Up 包装标准配件



* Denotes Standard Build 表示标准配置，选配件须注明编号

CB 70

额定值：70A 60%，50A 100% 暂载率。切割厚度：18-24mm。
Rating: 70A 60%, 50A 100% duty. Cutting Thickness: 18-24mm.



Model 型号		
Description 描述	Length 长度	Part Number 编号
CB70 1/4G 接口 Plasma Cutting Torch	6m	NPA1323G
CB70 Adaptor 中央插头 Plasma Cutting Torch	6m	NPA1322G

Components			
No.	Part Number	Description	No. Part Number Description
1	NCV0010	Stand Off Guide 隔离簧	9 NBX0628 Trigger Button 扳机按钮
2	NPC0032	Outside Nozzle 外喷嘴	10 NBW0243BG Handle 双色手柄
3	NPD0088-10	Cutting Tip 50A 电极喷嘴	11 NBW0246 Handle Locking Nut 手柄锁扣
	NPD0098-12	Cutting Tip 70A 电极喷嘴	12 NPH81245YT Cable Assembly 6m 电缆总成 6m
4	NPE0007	Swirl Ring 涡流环	13 NCY0002 Back Cable Support 后尾护套
5	NPR0063	Electrode 电极	14 NBW0195 Back Handle 后枪壳
6	NPF0065	Torch Head Kit 枪头	15 NBW0174 Locking Nut 中央插头锁母
7	NFH0778N	Elastic Pin 弹性插针	16 NPY0018G Central Connector 中央插头
8	NBX5833CH	Safety Trigger 扳机 (橙黑)	

CB 70 WEAR PARTS

All our consumable parts are interchangeable with the original OEM specification
Production Materials sourced from qualified top tier supplier (s).

NO.	Part Number	Description	Φ(mm)	L(mm)	Contact Short	Contact Long	Drag Short	Drag Long	Gouging	Product picture
1	NCV0010	Spacer Spring		18.5	●					
	NCV0073	Buggy	24.2	31	●					
2	NPC0032	Outside Nozzle		31.5	●	●				
3	NPD0085-98	Cutting Tip 50A	0.98	26.2	●					
	NPD0088-06	Cutting Tip 20A	0.65	12.3	●					
	NPD0088-08	Cutting Tip 40A	0.8	12.3	●					
	NPD0088-10	Cutting Tip 50A	1.0	12.3	●					
	NPD0088-11	Cutting Tip 60A	1.1	12.3	●					
	NPD0088-12	Cutting Tip 70A	1.2	12.3	●					
4	NPE0007	Swirl Ring			●	●				
5	NPR0063	Electrode		17.8	●					
	NPR0064	Electrode		34.8		●				
6	NFH0211				●					
	NFH0215					●				

● Torch Package Standard Wear Part Set Up 包装标准配件
 Contact Short
 Contact Long
 Drag Short
 Drag Long
 Gouging

* Denotes Standard Build 表示标准配置，选配件须注明编号

CB 100

额定值：100A 60%，70A 100% 暂载率。切割厚度：24-30mm。
Rating: 100A 60%, 70A 100% duty. Cutting Thickness: 24-30mm.

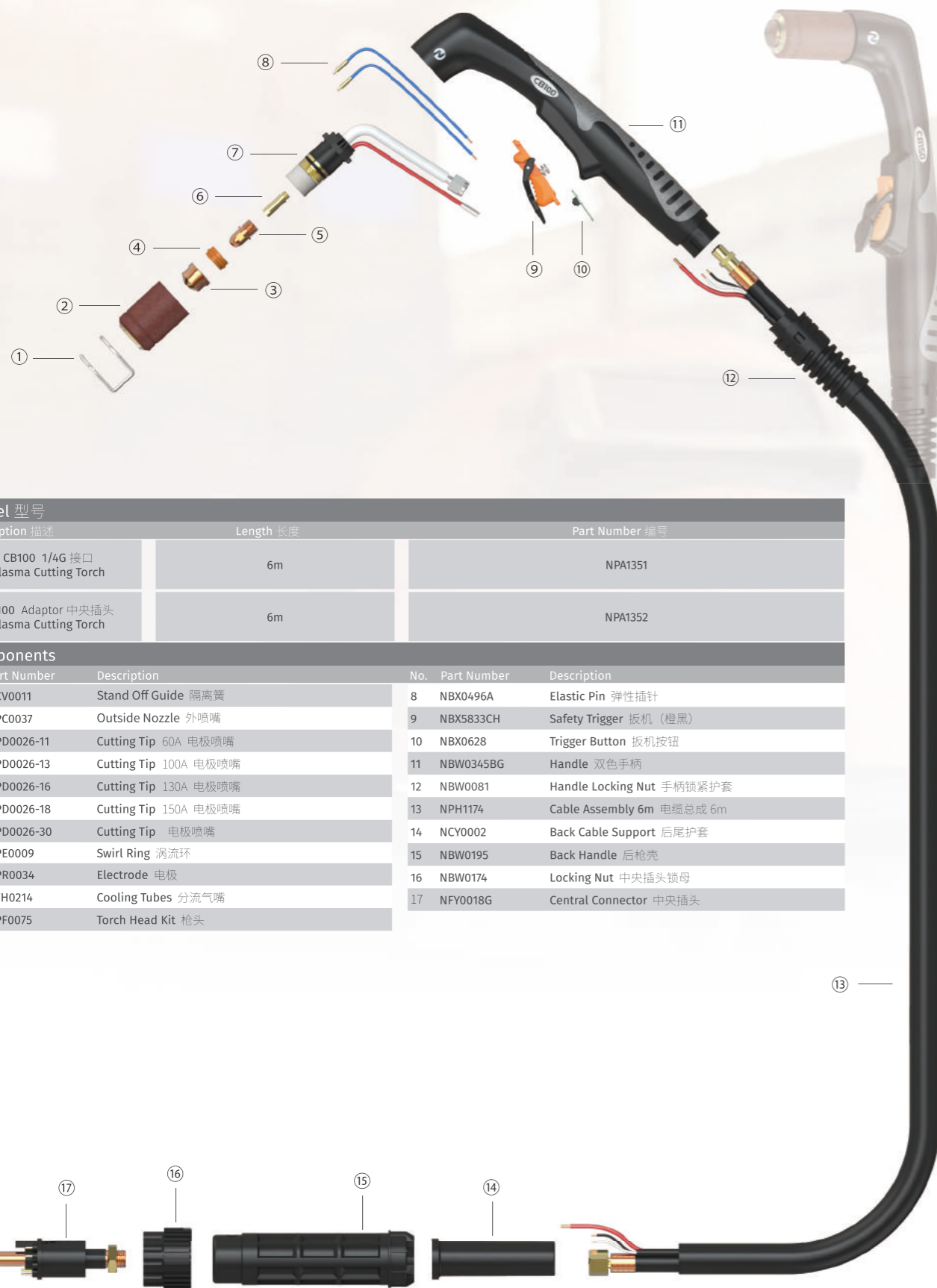

Model 型号		
Description 描述	Length 长度	Part Number 编号
CB100 1/4G 接口 Plasma Cutting Torch	6m	NPA1351
CB100 Adaptor 中央插头 Plasma Cutting Torch	6m	NPA1352

Components			
No.	Part Number	Description	No. Part Number Description
1	NCV0011	Stand Off Guide 隔离簧	8 NBX0496A Elastic Pin 弹性插针
2	NPC0037	Outside Nozzle 外喷嘴	9 NBX5833CH Safety Trigger 扳机 (橙黑)
3	NPD0026-11	Cutting Tip 60A 电极喷嘴	10 NBX0628 Trigger Button 扳机按钮
	NPD0026-13	Cutting Tip 100A 电极喷嘴	11 NBW0345BG Handle 双色手柄
	NPD0026-16	Cutting Tip 130A 电极喷嘴	12 NBW0081 Handle Locking Nut 手柄锁紧护套
	NPD0026-18	Cutting Tip 150A 电极喷嘴	13 NPH1174 Cable Assembly 6m 电缆总成 6m
	NPD0026-30	Cutting Tip 电极喷嘴	14 NPY0002 Back Cable Support 后尾护套
4	NPE0009	Swirl Ring 涡流环	15 NBW0195 Back Handle 后枪壳
5	NPR0034	Electrode 电极	16 NBW0174 Locking Nut 中央插头锁母
6	NFH0214	Cooling Tubes 分流气嘴	17 NPY0018G Central Connector 中央插头
	NPF0075	Torch Head Kit 枪头	

CB 100 WEAR PARTS

All our consumable parts are interchangeable with the original OEM specification
Production Materials sourced from qualified top tier supplier (s).

NO.	Part Number	Description	Φ(mm)	L(mm)	Contact Short	Contact Long	Drag Short	Drag Long	Gouging	Product picture
1	NCV0008	Shield Cap		32.5		●				
	NCV0011	Spacer Spring		23	●					
	NCV0012	Double Pointed Spacer		30	●					
	NCV0013	Stand Off Guide		33					●	
	NCV0021	Buggy		32.8	40.6	●				
	NCV0038	Shield Cap		17				●		
2	NPC0037	Outside Nozzle		44.1	●			●		
	NPC0038	Shield Cap Body		43.3		●	●	●		
3	NPD0025-14	Cutting Tip 100A	1.4	34.9				●		
	NPD0025-16	Cutting Tip 130A	1.6	34.9				●		
	NPD0025-18	Cutting Tip 150A	1.8	34.9				●		
	NPD0026-11	Cutting Tip 60A	1.1	14.1	●					
	NPD0026-13	Cutting Tip 100A	1.3	14.1	●					
	NPD0026-16	Cutting Tip 60A	1.6	14.1	●					
	NPD0026-18	Cutting Tip 130A	1.8	14.1	●					
	NPD0026-24	Cutting Tip 150A	2.4	14.1					●	
	NPD0026-30	Cutting Tip	3.0	14.1					●	
	NPD0028-13	Cutting Tip 100A	1.3	14				●		
4	NPD0028-16	Cutting Tip 130A	1.6	14				●		
	NPD0028-18	Cutting Tip 150A	1.8	14				●		
	NPD0030-11	Cutting Tip 60A	1.1	35.7				●		
	NPE0009	Swirl Ring			●	●	●	●	●	
5	NPR0034	Electrode		22	●			●		
	NPR0045	Electrode		43		●				
6	NFH0214	Cooling Tube			●	●	●	●		

● Torch Package Standard Wear Part Set Up 包装标准配件

● Contact Short

● Contact Long

● Drag Short

● Drag Long

● Gouging

* Denotes Standard Build 表示标准配置，选配件须注明编号

CB 150

额定值：150A 60%，110A 100% 暂载率。切割厚度：35-40mm。
Rating: 150A 60%, 110A 100% duty. Cutting Thickness: 35-40mm.



Model 型号		
Description 描述	Length 长度	Part Number 编号
CB150 1/4G 接口 Plasma Cutting Torch	6m	NPA1371
CB150 Adaptor 中央插头 Plasma Cutting Torch	6m	NPA1372

Components			
No.	Part Number	Description	No. Part Number Description
1	NCV0011	Stand Off Guide 隔离簧	10 NBX0496A Elastic Pin 弹性插针
2	NPC0002	Outside Nozzle 外喷嘴	11 NBX5833CH Safety Trigger 扳机 (橙黑)
3	NPD0026-11	Cutting Tip 60A 电极喷嘴	12 NBX0628 Trigger Button 扳机按钮
	NPD0026-13	Cutting Tip 100A 电极喷嘴	13 NBW0345BG Handle 双色手柄
	NPD0026-16	Cutting Tip 130A 电极喷嘴	14 NBW0081 Handle Locking Nut 手柄锁紧护套
	NPD0026-18	Cutting Tip 150A 电极喷嘴	15 NPH1171 Cable Assembly 6m 电缆总成 6m
	NPD0026-30	Cutting Tip 电极喷嘴	16 NCY0002 Back Cable Support 后尾护套
4	NPE0009	Swirl Ring 涡流环	17 NBW0195 Back Handle 后枪壳
5	NPR0034	Electrode 电极	18 NBW0174 Locking Nut 中央插头锁母
	NFH0213	Cooling Tubes 分流气嘴	19 NFY0018G Central Connector 中央插头
	NPF0080	Torch Head Kit 枪头	
	NPF0081	Removable Torch Head Kit 可拆枪头	
	NFH0619	Removable Insulator 可拆卸绝缘体	

CB 150 WEAR PARTS

All our consumable parts are interchangeable with the original OEM specification
Production Materials sourced from qualified top tier supplier (s).

NO.	Part Number	Description	Φ(mm)	L(mm)	Contact Short	Contact Long	Drag Short	Drag Long	Gouging	Product picture
1	NCV0008	Shield Cap		32.5		●				
	NCV0011	Spacer Spring		23	●					
	NCV0012	Double Pointed Spacer		30	●					
	NCV0013	Stand Off Guide		33					●	
	NCV0021	Buggy		32.8	40.6	●				
	NCV0038	Shield Cap		17					●	
2	NPC0002	Outside Nozzle		52.1	●			●		
3	NPD0025-14	Cutting Tip 100A	1.4	34.9				●		
	NPD0025-16	Cutting Tip 130A	1.6	34.9				●		
	NPD0025-18	Cutting Tip 150A	1.8	34.9				●		
	NPD0026-11	Cutting Tip 60A	1.1	14.1	●					
	NPD0026-13	Cutting Tip 100A	1.3	14.1	●					
	NPD0026-16	Cutting Tip 60A	1.6	14.1	●					
	NPD0026-18	Cutting Tip 130A	1.8	14.1	●					
	NPD0026-24	Cutting Tip 150A	2.4	14.1				●		
	NPD0026-30	Cutting Tip	3.0	14.1				●		
	NPD0028-13	Cutting Tip 100A	1.3	14				●		
	NPD0028-16	Cutting Tip 130A	1.6	14				●		
	NPD0028-18	Cutting Tip 150A						●		
4	NPD0030-11	Cutting Tip 60A	1.1	35.7			●	●		
4	NPE0009	Swirl Ring	1.8	14	●	●	●	●	●	
5	NPR0034	Electrode		22	●		●	●		
	NPR0045	Electrode		43		●				
6	NFH0213	Cooling Tube			●	●	●	●		

● Torch Package Standard Wear Part Set Up 包装标准配件

● Contact Short

● Contact Long

● Drag Short

● Drag Long

● Gouging

* Denotes Standard Build 表示标准配置，选配件须注明编号

NP Range



CNC 精密加工及高质量工程材料。
CNC machined consumables part and aerospace polymers.



人机工学设计, 实用、耐用型枪壳。
Ergonomic, solid handle design.



增加安全防护板, 避免意外发生。
A mechanical lever fitted to the trigger for user safety.



可适配多种后尾接头。
Terminations are offered in a "direct to machine" or central connector configuration.

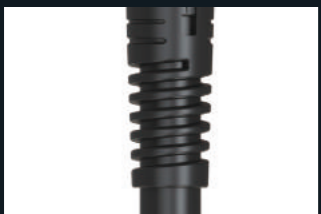

灵活的支撑设计。
Spiral design helps support the cable and offer great all day comfort use.

PT 31

额定值: 30A 60% 暂载率。切割厚度: 4-6mm。
Rating: 30A 60% duty. Cutting Thickness: 4-6mm.



Technical Data 参数	PT 31	SG 55	AG 60	NP 80
Cooling Method: 冷却方式	Air-Cooled	Air-Cooled	Air-Cooled	Air-Cooled
Rating: 额定电流	30A	60A	60A	80A
Duty Cycle: 暂载率	60%	60%	60%	60%
Cutting Thickness: 切割厚度	4-6mm	6-16mm	6-16mm	8-30mm

High Frequency 高频等离子割枪

Order Part No.	1/4G	4M	NPA3102G	NPA6001G-A	NPA6001G-B
		5M			
CENTRAL ADAPTOR	4M	4M	NPA3104G		NPA6004G
		5M			NPA1113
M16X1.5	4M	4M			NPA1110
		5M			NPA1110

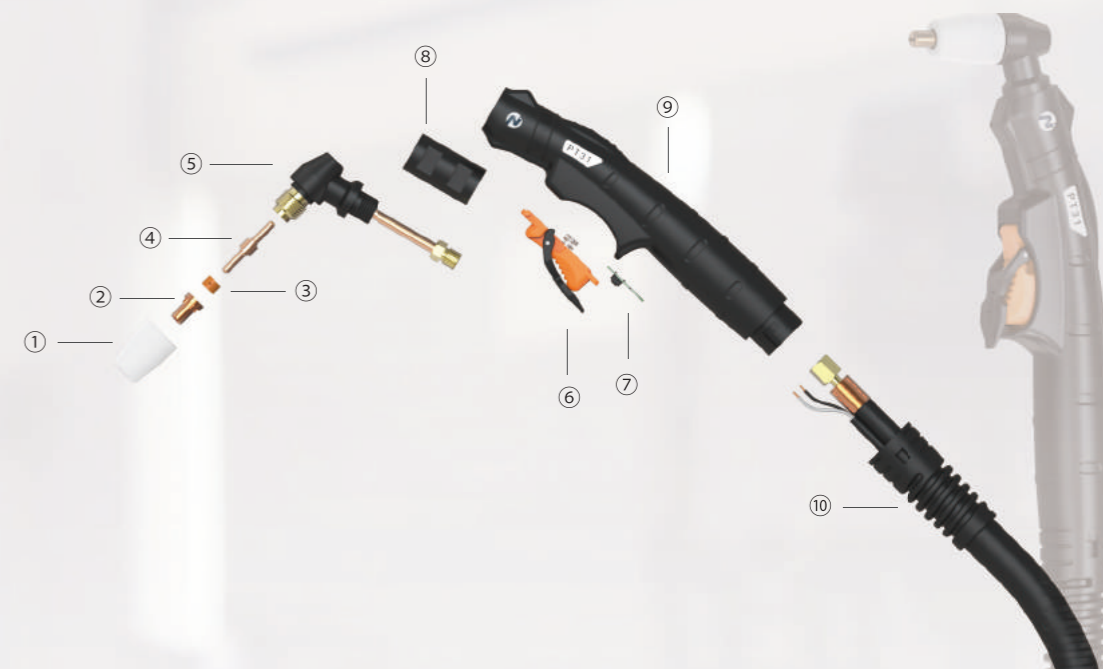

Model 型号	Description 描述	Length 长度	Part Number 编号
PT31 1/4G 接口 Plasma Cutting Torch		4m	NPA3102G
PT31 Adaptor 中央插头 Plasma Cutting Torch		4m	NPA3104G

Components				
Part Number	Description	No.	Part Number	Description
1	NPC0057 Creamic Nozzle 陶瓷喷嘴	10	NBW0081	Handle Locking Nut 手柄锁紧护套
2	NPD0022-10 Cutting Tip 30A 电极喷嘴	11	NPH3100	Cable Assembly 4m 电缆总成 4m
3	NPE0014 Swirl Ring 涡流环	12	NCY0002	Back Cable Support 后尾护套
4	NPR0030 Electrode 电极	13	NBW0195	Back Handle 后枪壳
5	NPF1071 Torch Head Kit 枪头	14	NBW0174	Locking Nut 中央插头锁母
6	NBX5833CH Safety Trigger 扳机 (橙黑)	15	NFY0018G	Central Connector 中央插头
7	NBX0628 Trigger Button 扳机按钮			
8	NBW0308 Adaptor 适配器			
9	NBW0480 Handle 手柄			

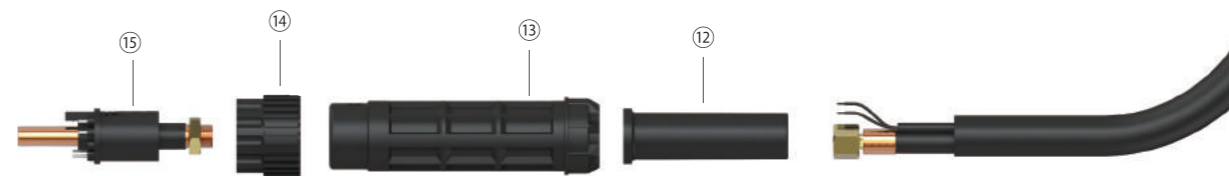





* Denotes Standard Build 表示标准配置, 选配件须注明编号

PT 31 WEAR PARTS

All our consumable parts are interchangeable with the original OEM specification
Production Materials sourced from qualified top tier supplier (s).

NO.	Part Number	Description	Φ(mm)	L(mm)					Product picture	
					Contact Short	Contact Long	Drag Short	Drag Long		Gouging
1	NCV1118N	Creamic Nozzle			●					
2	NPD0022-10	Cutting Tip 30A	1.0		●					
3	NPE0014	Swirl Ring			●					
4	NPR0030	Electrode		30.5	●					

● Torch Package Standard Wear Part Set Up 包装标准配件
 Contact Short
 Contact Long
 Drag Short
 Drag Long
 Gouging

SG 55

额定值：60A 60% 暂载率。切割厚度：6-16mm。
Rating: 60A 60% duty. Cutting Thickness: 6-16mm.

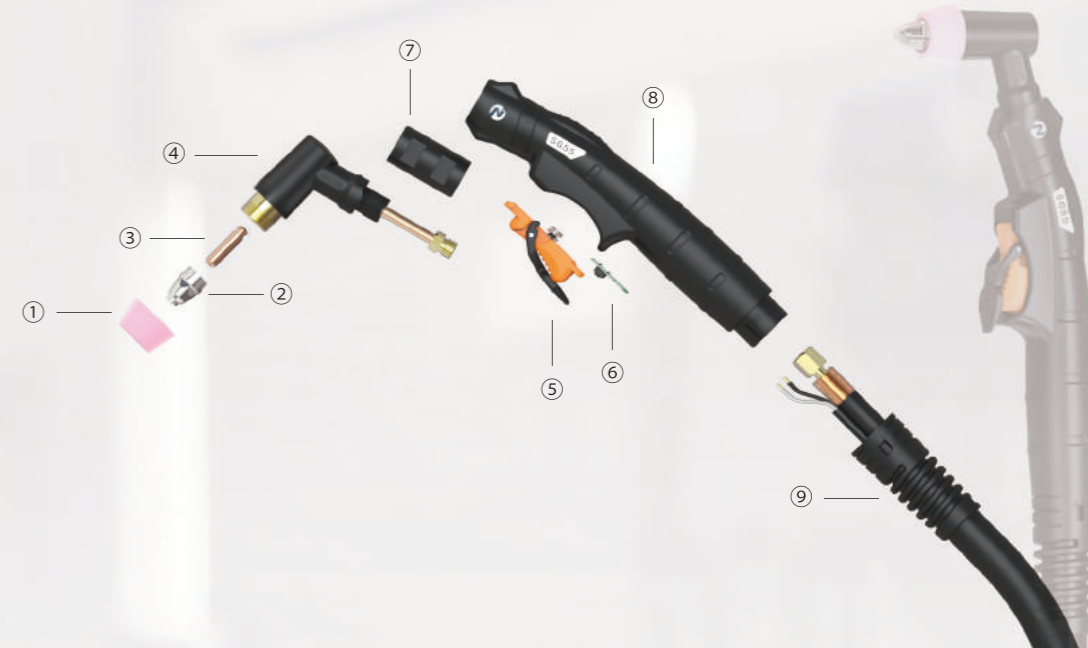

Model 型号	Description 描述	Length 长度	Part Number 编号
SG55 1/4G 接口 Plasma Cutting Torch		4m	NPA6001G-A

Components					
No.	Part Number	Description	No.	Part Number	Description
1	NPC0061	Creamic Nozzle 陶瓷喷嘴	10	NPH6000	Cable Assembly 4m 电缆总成 4m
2	NPD0055-12	Cutting Tip 60A 电极喷嘴	11	NCY0002	Back Cable Support 后尾护套
3	NPR0055	Electrode 电极	12	NBW0195	Back Handle 后枪壳
4	NPF6055	Torch Head Kit 枪头	13	NBW0174	Locking Nut 中央插头锁母
5	NBX5833	Safety Trigger 扳机 (橙黑)	14	NFY0018G	Central Connector 中央插头
6	NBX0628	Trigger Button 扳机按钮			
7	NBW0308	Adaptor 适配器			
8	NBW0480	Handle 手柄			
9	NBW0081	Handle Locking Nut 手柄锁紧护套			

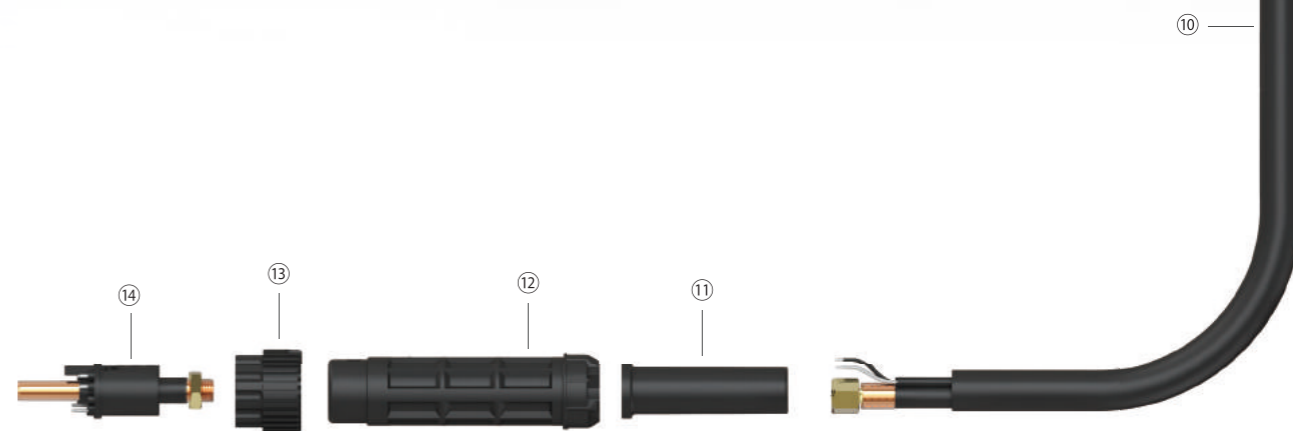





* Denotes Standard Build 表示标准配置，选配件须注明编号

SG 55 WEAR PARTS

All our consumable parts are interchangeable with the original OEM specification
Production Materials sourced from qualified top tier supplier (s).

NO.	Part Number	Description	Φ(mm)	L(mm)						Product picture	
					Contact Short	Contact Long	Drag Short	Drag Long	Gouging		
1	NPC0061	Creamic Nozzle			●						
2	NPD0055-10	Cutting Tip 30A	1.0								
	NPD0055-11	Cutting Tip 40A	1.1								
	NPD0055-12	Cutting Tip 50A	1.2	●							
	NPD0055-13	Cutting Tip 60A	1.3	●							
3	NPR0055	Electrode			●						

● Torch Package Standard Wear Part Set Up 包装标准配件
 Contact Short
 Contact Long
 Drag Short
 Drag Long
 Gouging

AG 60

额定值：60A 60% 暂载率。切割厚度：6-16mm。
Rating: 60A 60% duty. Cutting Thickness: 6-16mm.



Model 型号		
Description 描述	Length 长度	Part Number 编号
AG60 1/4G 接口 Plasma Cutting Torch	4m	NPA6001G-B
AG60 Adaptor 中央插头 Plasma Cutting Torch	4m	NPA6004G

Components					
No.	Part Number	Description	No.	Part Number	Description
1	NCV0060	Stand Off Guide 隔离黄	10	NPH6000-H	Cable Assembly 4m 电缆总成 4m
2	NPC0060	Creamic Nozzle 陶瓷喷嘴	11	NCY0002	Back Cable Support 后尾护套
3	NPD0055-12	Cutting Tip 60A 电极喷嘴	12	NBW0195	Back Handle 后枪壳
4	NPR0055	Electrode 电极	13	NBW0174	Locking Nut 中央插头锁母
5	NPF6055-HZ	Torch Head Kit 枪头	14	NFY0018G	Central Connector 中央插头
6	NBX5833	Safety Trigger 扳机 (橙黑)			
7	NBX0628	Trigger Button 扳机按钮			
8	NBW0480	Handle 手柄			
9	NBW0081	Handle Locking Nut 手柄锁紧护套			

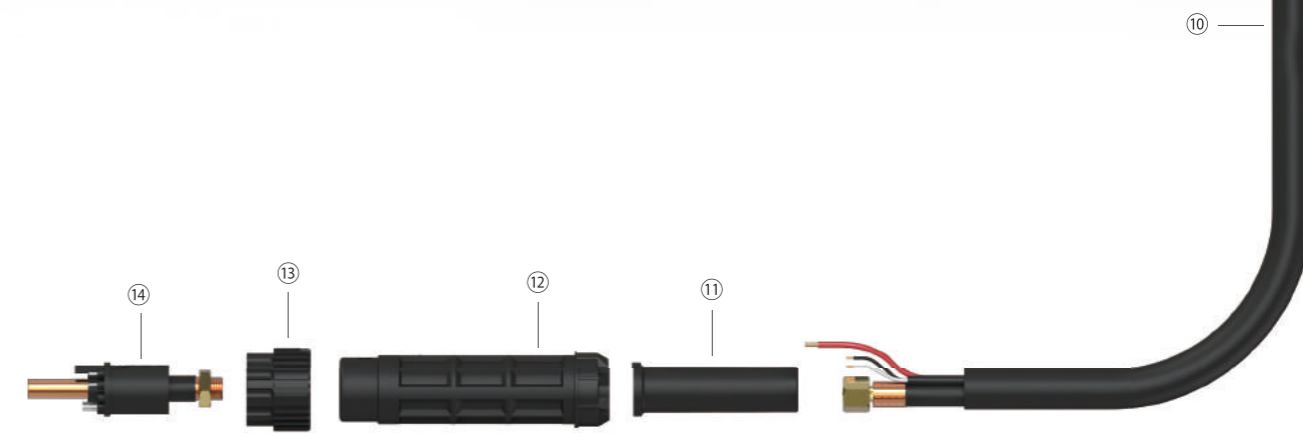

* Denotes Standard Build 表示标准配置，选配件须注明编号

AG 60 WEAR PARTS

All our consumable parts are interchangeable with the original OEM specification
Production Materials sourced from qualified top tier supplier (s).

NO.	Part Number	Description	Φ(mm)	L(mm)	Contact Short	Contact Long	Drag Short	Drag Long	Gouging	Product picture
1	NCV0060	Stand Off Guide								
2	NPC0060	Ceramic Nozzle			●					
3	NPD0055-10	Cutting Tip 30A	1.0							
	NPD0055-11	Cutting Tip 40A	1.1							
	NPD0055-12	Cutting Tip 50A	1.2		●					
	NPD0055-13	Cutting Tip 60A	1.3		●					
4	NPR0055	Electrode			●					

● Torch Package Standard Wear Part Set Up 包装标准配件
 Contact Short
 Contact Long
 Drag Short
 Drag Long
 Gouging

NP 80

额定值：80A 60% 暂载率。切割厚度：8-30mm。
Rating: 80A 60% duty. Cutting Thickness: 8-30mm.



Model 型号	Description 描述	Length 长度	Part Number 编号
NP80 M16X1.5 接口 Plasma Cutting Torch		4m	NPA1110
NP80 Adaptor 中央插头 Plasma Cutting Torch		4m	NPA1113

Components					
No.	Part Number	Description	No.	Part Number	Description
1	NCV8101D	Stand Off Guide 隔离簧	8	NBW0480	Handle 手柄
2	NPC0068	Ceramic Nozzle 陶瓷喷嘴	9	NBW0081	Handle Locking Nut 手柄锁紧护套
3	NPD0084-13	Cutting Tip 60A 电极喷嘴	10	NPH1112	Cable Assembly 5m 电缆总成 5m
	NPD0084-15	Cutting Tip 80A 电极喷嘴	11	NCY0002	Back Cable Support 后尾护套
	NPD0084-17	Cutting Tip 100A 电极喷嘴	12	NBW0195	Back Handle 后枪壳
4	NPR0070A	Electrode 电极	13	NBW0174	Locking Nut 中央插头锁母
5	NPF1070B	Torch Head Kit 枪头	14	NFY0018G	Central Connector 中央插头
6	NBX5833CH	Safety Trigger 扳机 (橙黑)			
7	NBX0628	Trigger Button 扳机按钮			

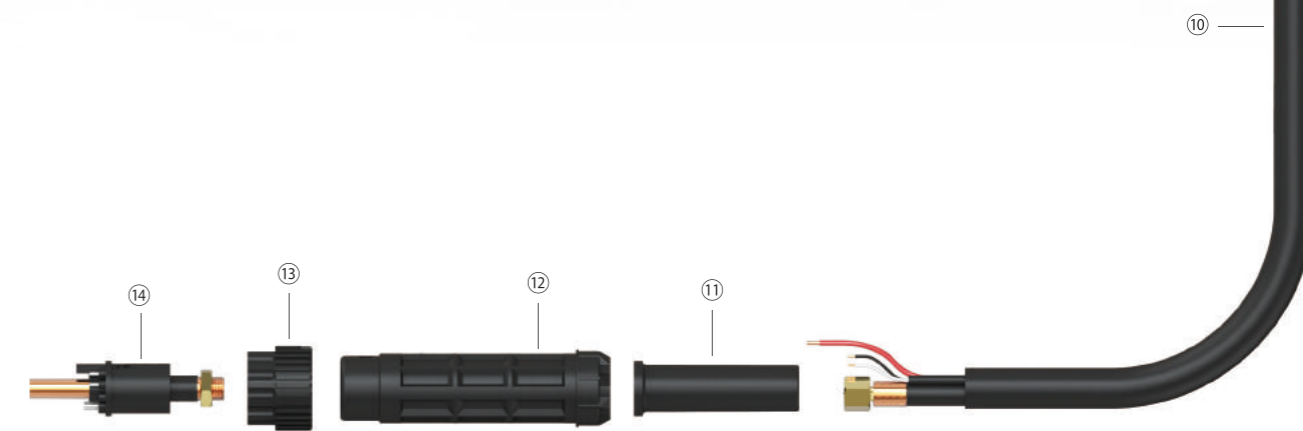

* Denotes Standard Build 表示标准配置，选配件须注明编号

NP 80 WEAR PARTS

All our consumable parts are interchangeable with the original OEM specification
Production Materials sourced from qualified top tier supplier (s).

NO.	Part Number	Description	Φ(mm)	L(mm)	Contact Short	Contact Long	Drag Short	Drag Long	Gouging	Product picture
1	NCV8101N	Stand Off Guide			●					
	NCV8101D	Stand Off Guide			●					
2	NPC0068				●					
3	NPD0084-13	Cutting Tip 60A	1.3		●					
	NPD0084-15	Cutting Tip 80A	1.5		●					
	NPD0084-17	Cutting Tip 100A	1.7		●					
4	NPR0070	Electrode			●					

● Torch Package Standard Wear Part Set Up 包装标准配件 ◐ Contact Short ◑ Contact Long ◒ Drag Short ◓ Drag Long ◔ Gouging

加长枪颈的 NP80

在不同的应用领域, 需要加长枪颈来满足切割需求, 为此我们开发了加长枪颈的NP80来满足用户需求, 枪颈可以加长100-1000mm, 并且在加长300mm以上的枪颈配备了辅助手柄。



NU Range



CNC 精密加工及高质量工程材料。
CNC machined consumables part and aerospace polymers.



人机工学设计, 实用、耐用型枪壳。
Ergonomic, solid handle design.



增加安全防护板, 避免意外发生。
A mechanical lever fitted to the trigger for user safety.



可适配多种后尾接头。
Terminations are offered in a "direct to machine" or central connector configuration.



灵活的支撑设计。
Spiral design helps support the cable and offer great all day comfort use.



Technical Data 参数	NU 35K	NU 45
Cooling Method 冷却方式	Air-Cooled	Air-Cooled
Rating : 额定电流	30A	40A
Duty Cycle: 暂载率	35%	60%
Cutting Thickness: 切割厚度	6-12mm	8-16mm

Without High Frequency 低频等离子割枪

Order Part No.	1/4G	4M	NPA0409U	
		5M		
CENTRAL ADAPTOR		6M		NPA0165U
		4M		
		5M		
		6M		NPA0166U

NU 35K

额定值：30A 35% 暂载率。切割厚度：6-12mm。
 Rating: 30A 35% duty. Cutting Thickness: 6-12mm.

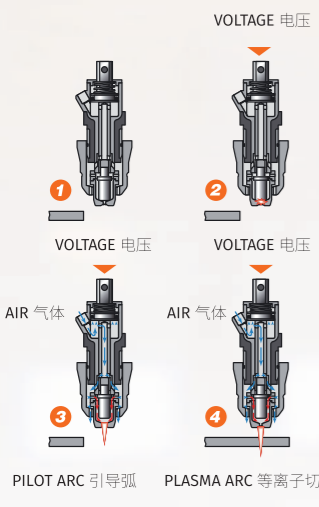
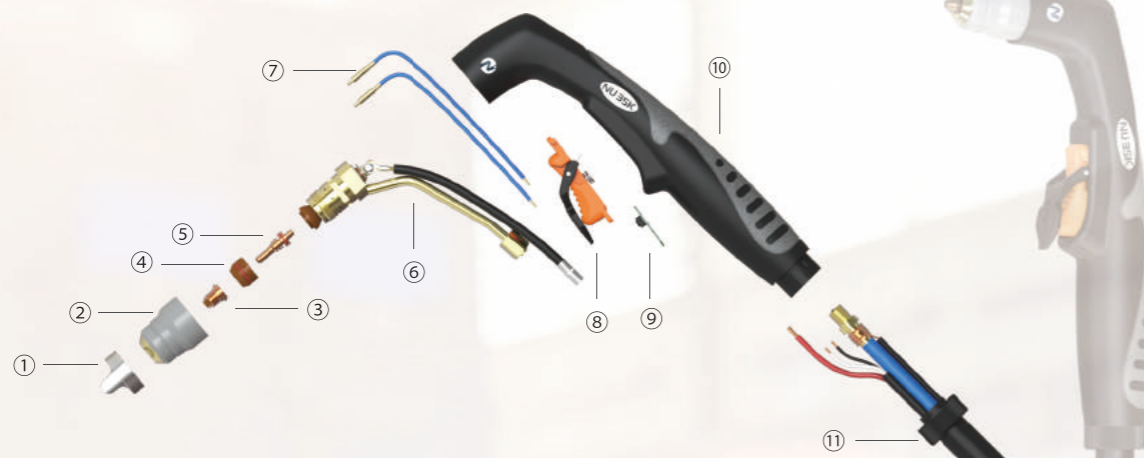

1. Torch off. 切割枪处于关闭状态。
2. By pressing the trigger the torch will be fed by the current thus causing a temporary short circuit between electrode and tip.
按下开关时，切割枪通电，在很短的时间内电流在电极和电极喷嘴之间形成一个回路。
3. The air then pushes up the small piston, thus creating, between the electrode and the tip, the distance needed to strike the pilot arc.
有一格很短时间延时的气流到达枪头，将电极喷嘴向外推动一段很小的间距，在电极和电极喷嘴之间形成一格很小的引弧间距。
4. By positioning the torch on the part to be cut, the plasma arc will strike.
气流将电弧从电极喷嘴内吹出，将枪头置于工件上，等离子电弧就成了切割弧。

For generators with compressor inside use

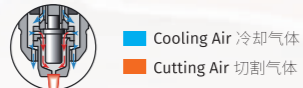
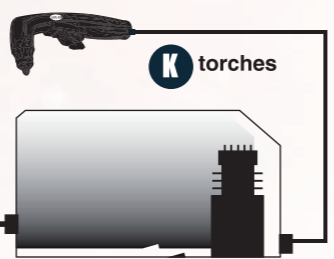

Model 型号	Description 描述	Length 长度	Part Number 编号
NU35K 1/4G 接口 Plasma Cutting Torch		4m	NPA0409U

No.	Part Number	Description	No.	Part Number	Description
1	NCV1116	Double Pointed Spacer 隔离簧支架	10	NBW0243BG	Handle 双色手柄
2	NPC0035	Outside Nozzle 外喷嘴	11	NBW0246	Handle Locking Nut 手柄锁扣
3	NPD0035	Cutting Tip 30A 电极喷嘴	12	NPH0298	Cable Assembly 6m 电缆总成 6m
4	NPE0035	Swirl Ring 涡流环	13	NCY0002	Back Cable Support 后尾护套
5	NPR0035	Electrode 电极	14	NBW0195	Back Handle 后枪壳
6	NPF1127N	Torch Head Kit 枪头	15	NBW0174	Locking Nut 中央插头锁母
7	NFH0778N	Elastic Pin 弹性插针	16	NFY0018G	Central Connector 中央插头
8	NBX5833CH	Safety Trigger 扳机 (橙黑)			
9	NBX0628	Trigger Button 扳机按钮			

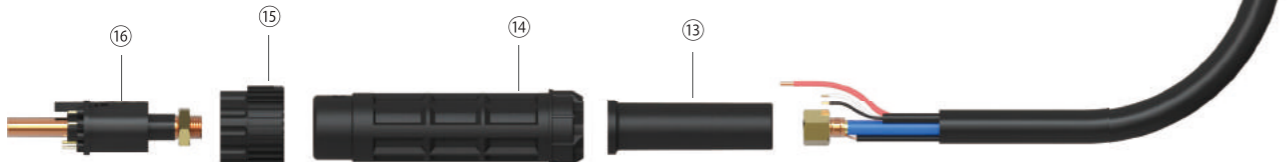

NU 35K WEAR PARTS

All our consumable parts are interchangeable with the original OEM specification
 Production Materials sourced from qualified top tier supplier (s).

NO.	Part Number	Description	Φ(mm)	L(mm)	Contact Short	Contact Long	Drag Short	Drag Long	Gouging	Product picture
1	NCV1116	Double Pointed Spacer	25	19	●					
2	NPC0035	Outside Nozzle		31.7	●					
3	NPD0035	Cutting Tip 30A	0.8	12.2	●					
4	NPE0035	Swirl Ring		12.6	●					
5	NPR0035	Electrode		25.5	●					

● Torch Package Standard Wear Part Set Up 包装标准配件
 ■ Contact Short ■ Contact Long ■ Drag Short ■ Drag Long ■ Gouging

* Denotes Standard Build 表示标准配置，选配件须注明编号

NU 45

额定值：40A 60% 暂载率。切割厚度：8-16mm。
Rating: 40A 60% duty. Cutting Thickness: 8-16mm.



NU 45 WEAR PARTS

All our consumable parts are interchangeable with the original OEM specification
Production Materials sourced from qualified top tier supplier (s).

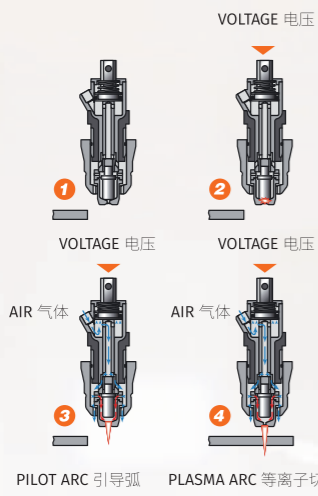

1. Torch off. 切割枪处于关闭状态。
2. By pressing the trigger the torch will be fed by the current thus causing a temporary short circuit between electrode and tip.
按下开关时，切割枪通电，在很短时间内电流在电极和电极喷嘴之间形成一个回路。
3. The air then pushes up the small piston, thus creating, between the electrode and the tip, the distance needed to strike the pilot arc.
有一格很短时间延时的气流到达枪头，将电极喷嘴向外推动一段很小的间距，在电极和电极喷嘴之间形成一格很小的引弧间距。
4. By positioning the torch on the part to be cut, the plasma arc will strike.
气流将电弧从电极喷嘴内吹出，将枪头置于工件上，等离子电弧就成了切割弧。

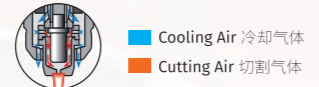

Model 型号	Description 描述	Length 长度	Part Number 编号
NU45 1/4G 接口 Plasma Cutting Torch		6m	NPA0165U
NU45 Adaptor 中央插头 Plasma Cutting Torch		6m	NPA0166U

Components					
No.	Part Number	Description	No.	Part Number	Description
1	NCV2053T	Shield Cap 保护帽	9	NBX0628	Trigger Button 扳机按钮
2	NPC2050Y	Outside Nozzle 外喷嘴	10	NTP3427	Handle 手柄
3	NPD7890T-08	Cutting Tip 40A 电极喷嘴	11	NEA0301	Steel Cable Support 弹簧护套
	NPD7890T-09	Cutting Tip 45A 电极喷嘴	12	NPH5000	Cable Assembly 4m 4m 电缆总成
4	NPR2047	Electrode 电极	13	NCY0002	Back Cable Support 后尾护套
5	NPE7886T	Swirl Ring 涡流环	14	NBW0195	Back Handle 后枪壳
6	NPF8795	Torch Head Kit 枪头	15	NBW0174	Locking Nut 中央插头锁母
7	NFH8639	Elastic Pin 弹性插针	16	NFY0018G	Central Connector 中央插头
8	NBX5833CH	Safety Trigger 扳机 (橙黑)			

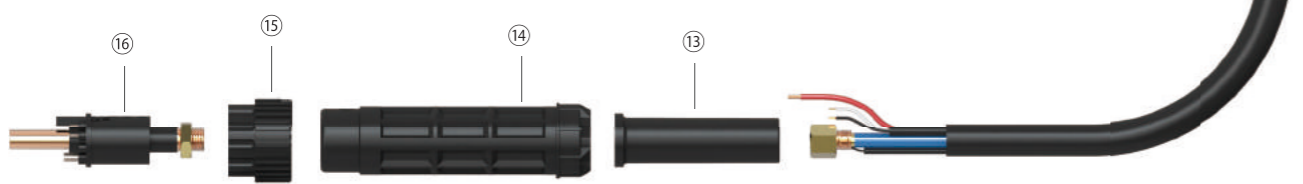

NO.	Part Number	Description	Φ(mm)	L(mm)						Product picture	
					Contact Short	Contact Long	Drag Short	Drag Long	Gouging		
1	NCV2053T	Shield Cap		16.3	●						
	NCV0006	Shield Cap		15.3					●		
2	NPC2050Y	Outside Nozzle		36	●						
3	NPD7890T	Cutting Tip 30A	0.8	15.2	●						
	NPD07878	Cutting Tip		15.5					●		
4	NPE7886T	Swirl Ring		25.5	●						
5	NPR2047	Electrode		25.5	●						

● Torch Package Standard Wear Part Set Up 包装标准配件
 Contact Short
 Contact Long
 Drag Short
 Drag Long
 Gouging

NSP Range



CNC 精密加工及高质量工程材料。
CNC machined consumables part and aerospace polymers.



实用、耐用型枪壳。
Solid handle design.

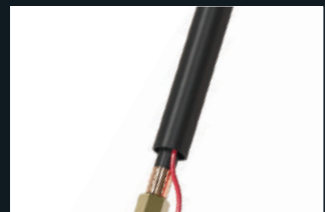

高导电性电缆。
Heavy duty metal jacket with hi conductivity inner copper tube.



可适配多种后尾接头。
Terminations are offered in a "direct to machine" or central connector configuration.

NO HF

低频引弧降低电磁干扰。
Less electromagnetic disturbance with consequent absence of problems for electronic control systems in automatic equipment.

NS 75P

额定值：70A 60%，50A 100% 暂载率。切割厚度：18-23mm。
Rating: 70A 60%, 50A 100% duty. Cutting Thickness: 18-23mm.

NO HF



Technical Data 参数	NS 75P	NS 80P	NS105P	NS 125P
Cooling Method: 冷却方式	Air-Cooled	Air-Cooled	Air-Cooled	Air-Cooled
Rating: 额定电流	70A 50A	80A 60A	100A 70A	120A 90A
Duty Cycle: 暂载率	60% 100%	60% 100%	60% 100%	60% 100%
Cutting Thickness: 切割厚度	18-23mm	20-30mm	25-30mm	25-35mm

Without High Frequency 低频频等离子割枪

Order Part No.	1/4G	4M				
		5M				
		6M	NPA1621	NPA8606P	NPA1684	NPA2261
CENTRAL ADAPTOR		4M				
		5M				
		6M	NPA1620	NPA8604P	NPA1682	NPA2260

NO HF

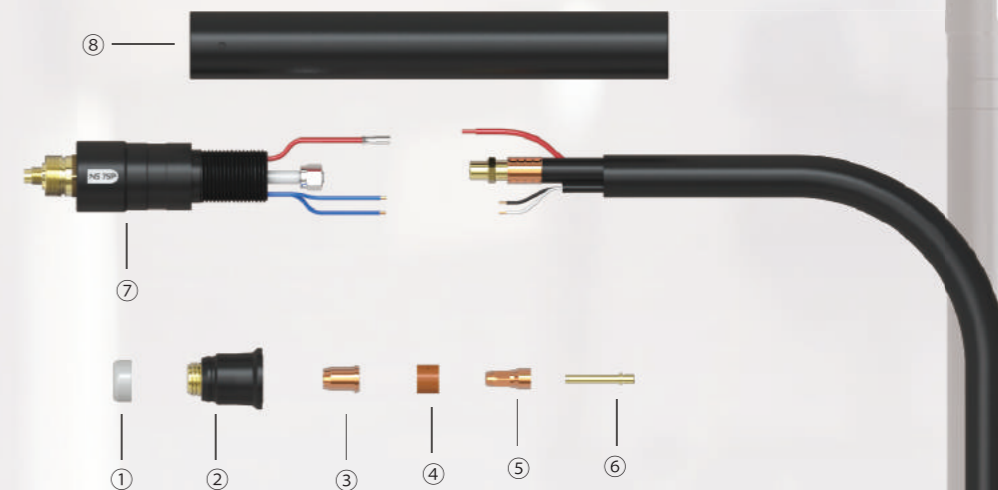

Model 型号	Description 描述	Length 长度	Part Number 编号
NS75P 1/4G 接口	Plasma Cutting Torch	6m	NPA1621
NS75P Adaptor 中央插头	Plasma Cutting Torch	6m	NPA1620

Components					
No.	Part Number	Description	No.	Part Number	Description
1	NCV0076	Shield Cap 保护帽	7	NPF0137	Torch Head Kit 枪头
2	NPC0114	Outside Nozzle 外喷嘴	8	NTP0061	Auto Handle 手柄
3	NPD0114-10	Cutting Tip 50A 电极喷嘴	9	NPH8261	Cable Assembly 电缆总成
	NPD0114-12	Cutting Tip 70A 电极喷嘴	10	NCY0002	Back Cable Support 后尾护套
4	NPE0112	Swirl Ring 涡流环	11	NBW0195	Back Handle 后枪壳
5	NPR0117	Electrode 电极	12	NBW0174	Locking Nut 中央插头锁母
6	NFH0647	Cooling Tube 分流气管	13	NFY0018G	Central Connector 中央插头

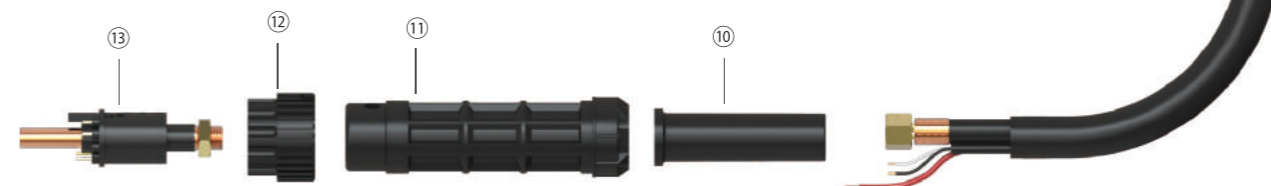



* Denotes Standard Build 表示标准配置，选配件须注明编号

NS 75P WEAR PARTS

All our consumable parts are interchangeable with the original OEM specification
Production Materials sourced from qualified top tier supplier (S).

NO.	Part Number	Description	Φ(mm)	L(mm)						Product picture
					Contact Short	Contact Long	Drag Short	Drag Long	Gouging	
1	NCV0076	Ceramic Protective Cap			●					
	NPC0114	Outside Nozzle		39.5	●					
2	NPD0114-10	Cutting Tip 50A	1.0	18.6	●					
	NPD0114-12	Cutting Tip 70A	1.2	18.6	●					
3	NPE0112	Swirl Ring			●					
4	NPR0117	Electrode		23.7	●					
5	NFH0647	Cooling Tube			●					

● Torch Package Standard Wear Part Set Up 包装标准配件
 Contact Short
 Contact Long
 Drag Short
 Drag Long
 Gouging

NS 80P

额定值：80A 60%，60A 100% 暂载率。切割厚度：20-30mm。
Rating: 80A 60%, 60A 100% duty. Cutting Thickness: 20-30mm.

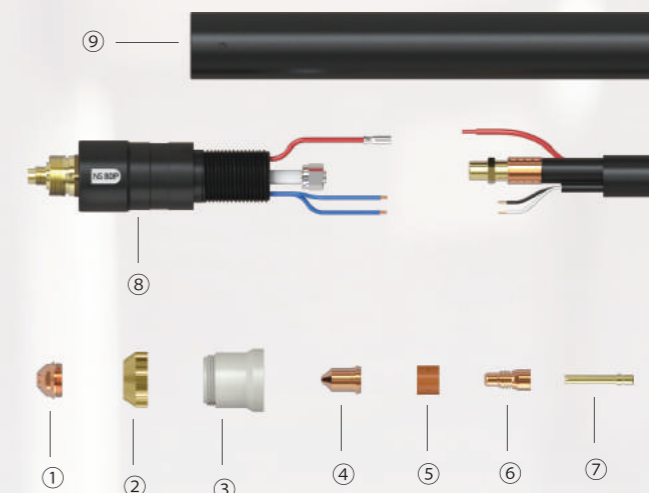

Model 型号		
Description 描述	Length 长度	Part Number 编号
NS80P 1/4G 接口 Plasma Cutting Torch	6m	NPA8606P
NS80P Adaptor 中央插头 Plasma Cutting Torch	6m	NPA8604P

Components					
No.	Part Number	Description	No.	Part Number	Description
1	NCV2056	Shield Cap 保护帽	8	NPF0137	Torch Head Kit 枪头
2	NCV2054	Shield Cap Body 保护帽座	9	NTP0061	Auto Handle 手柄
3	NPC0108	Outside Nozzle 外喷嘴	10	NPH8261	Cable Assembly 电缆总成
4	NPD0113-10	Cutting Tip 50A 电极喷嘴	11	NCY0002	Back Cable Support 后尾护套
	NPD0113-12	Cutting Tip 70A 电极喷嘴	12	NBW0195	Back Handle 后枪壳
	NPD0113-14	Cutting Tip 80A 电极喷嘴	13	NBW0174	Locking Nut 中央插头锁母
5	NPE0112	Swirl Ring 涡流环	14	NFY0018G	Central Connector 中央插头
6	NPR0113	Electrode 电极			
7	NFH0647	Cooling Tube 分流气管			



* Denotes Standard Build 表示标准配置，选配件请注明编号

NS 80P WEAR PARTS

All our consumable parts are interchangeable with the original OEM specification
Production Materials sourced from qualified top tier supplier (S).

NO.	Part Number	Description	Φ(mm)	L(mm)	Contact Short	Contact Long	Drag Short	Drag Long	Gouging	Product picture
1	NCV2056	Shield Cap					●			
2	NPCV2054	Shield Cap Body					●			
3	NPC0108	Outside Nozzle					●			
4	NPD0113-10	Cutting Tip 50A	1.0				●			
	NPD0113-12	Cutting Tip 70A	1.2				●			
	NPD0113-14	Cutting Tip 80A	1.4				●			
5	NPE0112	Swirl Ring					●			
6	NPR0113	Electrode					●			
7	NFH0647	Cooling Tube					●			

● Torch Package Standard Wear Part Set Up 包装标准配件
 Contact Short
 Contact Long
 Drag Short
 Drag Long
 Gouging

NS 105P

额定值: 100A 60%, 70A 100% 暂载率。切割厚度: 25-30mm。
Rating: 100A 60%, 70A 100% duty. Cutting Thickness: 25-30mm.

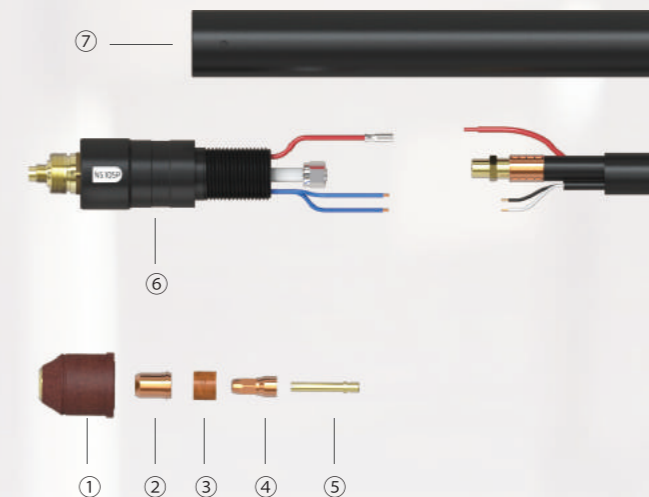

Model 型号	Description 描述	Length 长度	Part Number 编号
NS105P 1/4G 接口 Plasma Cutting Torch		6m	NPA1684
NS105P Adaptor 中央插头 Plasma Cutting Torch		6m	NPA1682

Components					
No.	Part Number	Description	No.	Part Number	Description
1	NPC0002	Outside Nozzle 外喷嘴	6	NPF0080	Torch Head Kit 枪头
2	NPD0026-11	Cutting Tip 60A 电极喷嘴	7	NTP0061	Auto Handle 手柄
	NPD0026-13	Cutting Tip 100A 电极喷嘴	8	NPH1171	Cable Assembly 6m 电缆总成 6m
	NPD0026-16	Cutting Tip 130A 电极喷嘴	9	NCY0002	Back Cable Support 后尾护套
	NPD0026-18	Cutting Tip 150A 电极喷嘴	10	NBW0195	Back Handle 后枪壳
	NPD0026-30	Cutting Tip 电极喷嘴	11	NBW0174	Locking Nut 中央插头锁母
3	NPE0009	Swirl Ring 涡流环	12	NFY0018G	Central Connector 中央插头
4	NPR0034	Electrode 电极			
5	NFH0213	Cooling Tube 分流气管			







* Denotes Standard Build 表示标准配置，选配件须注明编号

NS 105P WEAR PARTS

All our consumable parts are interchangeable with the original OEM specification
Production Materials sourced from qualified top tier supplier (s).

NO.	Part Number	Description	Φ(mm)	L(mm)						Product picture	
					Contact Short	Contact Long	Drag Short	Drag Long	Gouging		
1	NPC0118	Outside Nozzle		39.5	●						
2	NPD0119-10	Cutting Tip 50A	1.0	18.7	●						
	NPD0119-12	Cutting Tip 70A	1.2	18.7	●						
	NPD0119-14	Cutting Tip 100A	1.4	18.7	●						
3	NPE0112	Swirl Ring			●						
4	NPR0117	Electrode		23.7	●						
5	NFH0647	Cooling Tube			●						

● Torch Package Standard Wear Part Set Up 包装标准配件
 Contact Short
 Contact Long
 Drag Short
 Drag Long
 Gouging

NS 125P

额定值: 120A 60%, 90A 100% 暂载率。切割厚度: 25-35mm。
Rating: 120A 60%, 90A 100% duty. Cutting Thickness: 25-35mm.

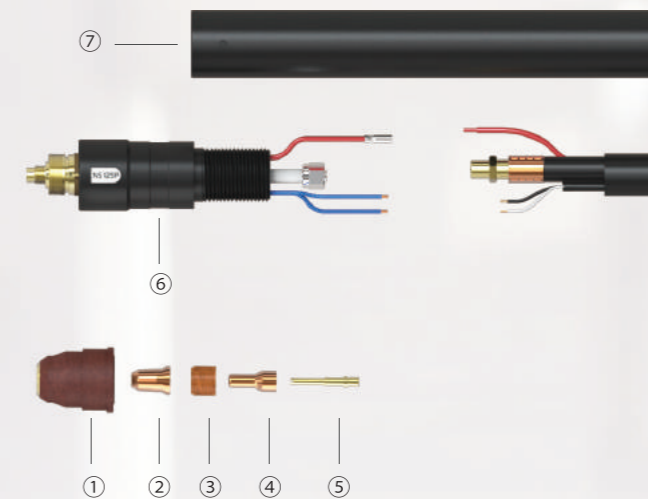

Model 型号		
Description 描述	Length 长度	Part Number 编号
NS125P 1/4G 接口 Plasma Cutting Torch	6m	NPA2261
NS125P Adaptor 中央插头 Plasma Cutting Torch	6m	NPA2260

Components					
No.	Part Number	Description	No.	Part Number	Description
1	NPC0179	Outside Nozzle 外喷嘴	8	NPH0405	Cable Assembly 6m 电缆总成 6m
2	NPD0179-13	Cutting Tip 80A 电极喷嘴	9	NCY0002	Back Cable Support 后尾护套
	NPD0179-14	Cutting Tip 100A 电极喷嘴	10	NBW0195	Back Handle 后枪壳
	NPD0179-15	Cutting Tip 120A 电极喷嘴	11	NBW0174	Locking Nut 中央插头锁母
3	NPE0179	Swirl Ring 涡流环	12	NFY0018G	Central Connector 中央插头
4	NPR0179	Electrode 电极			
5	NFH0979	Cooling Tube 分流气管			
6	NPF0135	Torch Head Kit 枪头			
7	NTP0061	Auto Handle 手柄			

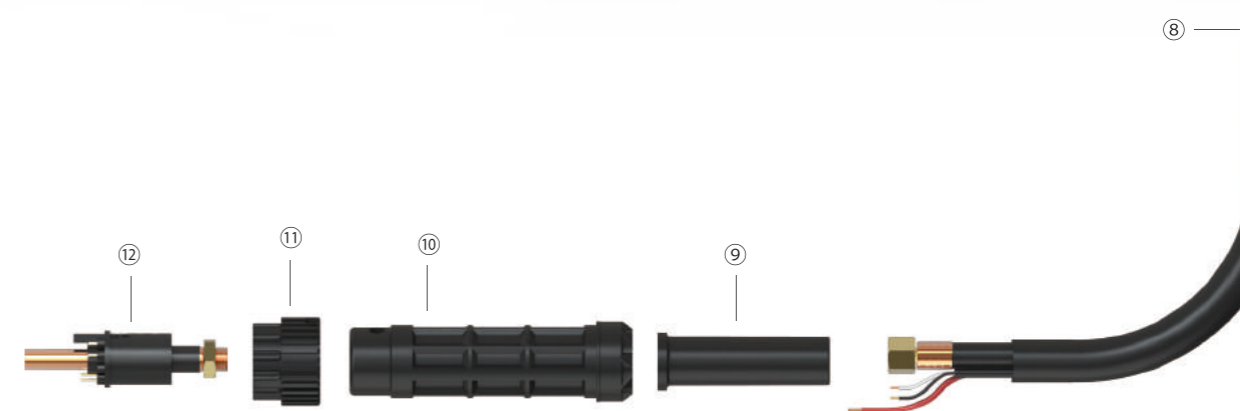

* Denotes Standard Build 表示标准配置, 选配件须注明编号

NS 125P WEAR PARTS

All our consumable parts are interchangeable with the original OEM specification
Production Materials sourced from qualified top tier supplier (s).

NO.	Part Number	Description	Φ(mm)	L(mm)					Product picture	
					Contact Short	Contact Long	Drag Short	Drag Long		Gouging
1	NPC0179	Outside Nozzle		39.5	●					
2	NPD0179-13	Cutting Tip 80A	1.3	20	●					
	NPD0179-14	Cutting Tip 100A	1.4	20	●					
	NPD0179-15	Cutting Tip 120A	1.5	20	●					
3	NPE0179	Swirl Ring		12.6	●					
4	NPR0179	Electrode		24.6	●					
5	NFH0979	Cooling Tube			●					

● Torch Package Standard Wear Part Set Up 包装标准配件

■ Contact Short ■ Contact Long ■ Drag Short ■ Drag Long ■ Gouging

NAP Range



CNC 精密加工及高质量工程材料。
CNC machined consumables part and aerospace polymers.



实用、耐用型枪壳。
Solid handle design.

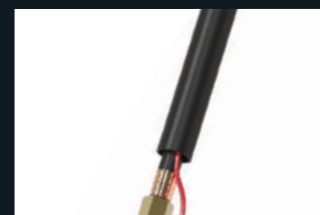

高导电性电缆。
Heavy duty metal jacket with hi conductivity inner copper tube.



可适配多种后尾接头。
Terminations are offered in a "direct to machine" or central connector configuration.



Technical Data 参数	NA 81P	NA 101P	NA 141P	NA 151P
Cooling Method: 冷却方式	Air-Cooled	Air-Cooled	Air-Cooled	Air-Cooled
Rating: 额定电流	80A 60A	100A 75A	140A 100A	150A 120A
Duty Cycle: 暂载率	60% 100%	60% 100%	60% 100%	60% 100%
Cutting Thickness: 切割厚度	20-25mm	25-30mm	35-40mm	35-40mm

High Frequency 高频等离子割枪

Order Part No.	1/4G	4M			
		5M			
CENTRAL ADAPTOR	6M	NPA0180	NPA0110	NPA0103	NPA0127
	4M				
	5M				
	6M	NPA0181	NPA0111	NPA0145	NPA0128

NA 81P

额定值：80A 60%，60A 100% 暂载率。切割厚度：20-25mm。
 Rating: 80A 60%, 60A 100% duty. Cutting Thickness: 20-25mm.



NA 81P WEAR PARTS

All our consumable parts are interchangeable with the original OEM specification
 Production Materials sourced from qualified top tier supplier (s).

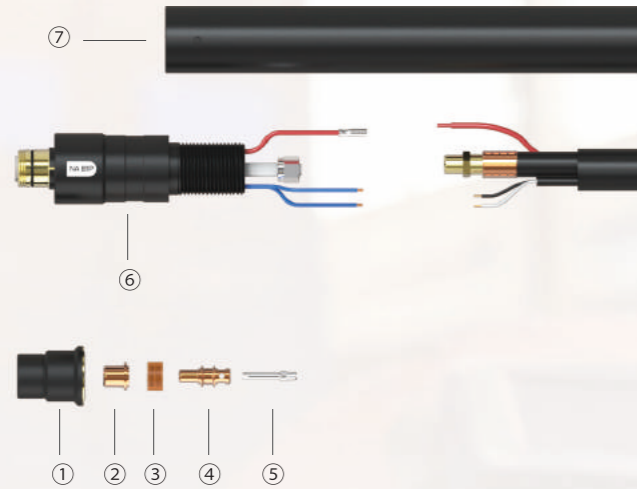

Model 型号	Description 描述	Length 长度	Part Number 编号
NA81P 1/4G 接口 Plasma Cutting Torch		6m	NPA0180
NA81P Adaptor 中央插头 Plasma Cutting Torch		6m	NPA0181

Components					
No.	Part Number	Description	No.	Part Number	Description
1	NPC0115	Outside Nozzle 外喷嘴	9	NCY0002	Back Cable Support 后尾护套
2	NPD0105-10	Cutting Tip 50A 电极喷嘴	10	NBW0195	Back Handle 后枪壳
	NPD0105-12	Cutting Tip 80A 电极喷嘴	11	NBW0174	Locking Nut 中央插头锁母
3	NPE0107	Swirl Ring 涡流环	12	NFY00186	Central Connector 中央插头
4	NPR0109	Electrode 电极			
5	NFH0560	Cooling Tube 分流气管			
6	NPF0140	Torch Head Kit 枪头			
7	NTP0061	Auto Handle 手柄			
8	NPH1260	Cable Assembly 6m 电缆总成 6m			

NO.	Part Number	Description	Φ(mm)	L(mm)	Contact Short	Contact Long	Drag Short	Drag Long	Gouging	Product picture
1	NPC0115	Outside Nozzle		35.4	●					
3	NPD0105-10	Cutting Tip 50A	1.0	13.3	●					
	NPD0105-12	Cutting Tip 80A	1.2	13.3	●					
4	NPE0107	Swirl Ring			●					
5	NPR0109	Electrode		27	●					
6	NFH0560	Cooling Tube			●					

● Torch Package Standard Wear Part Set Up 包装标准配件
 ■ Contact Short ■ Contact Long ■ Drag Short ■ Drag Long ■ Gouging

⑧

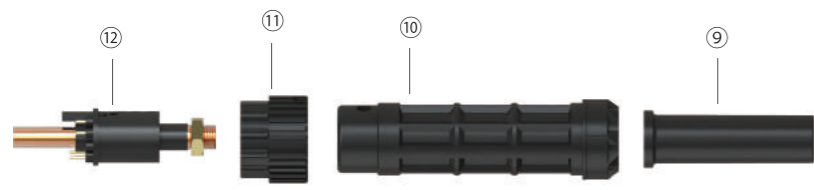

* Denotes Standard Build 表示标准配置，选配件请注明编号

NA 101P

额定值: 100A 60%, 75A 100% 暂载率。切割厚度: 25-30mm。
Rating: 100A 60%, 75A 100% duty. Cutting Thickness: 25-30mm.



NA 101P WEAR PARTS

All our consumable parts are interchangeable with the original OEM specification
Production Materials sourced from qualified top tier supplier (s).

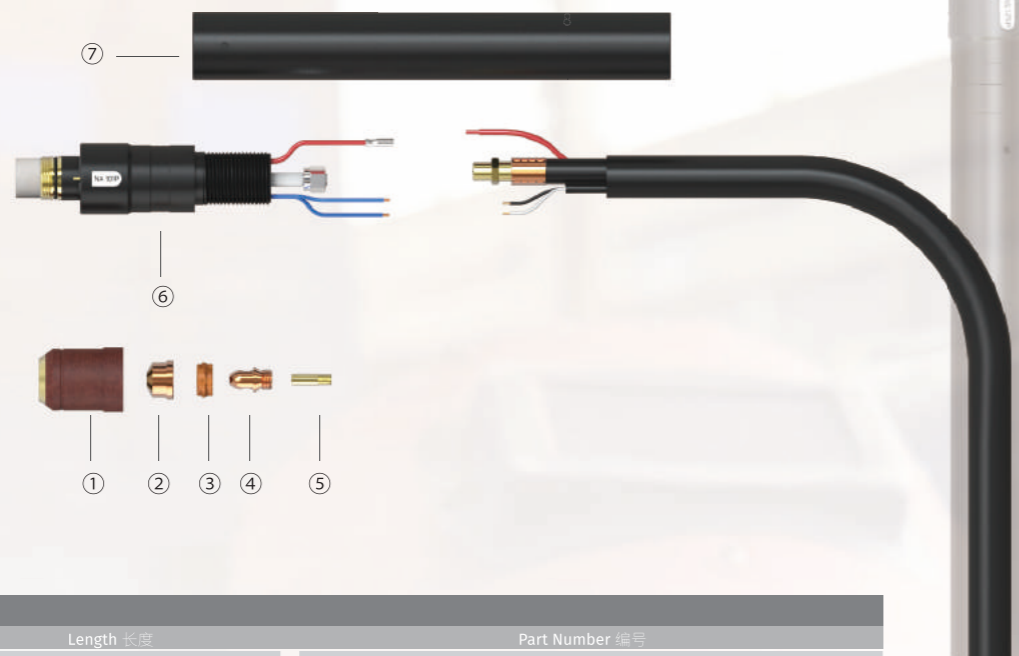

Model 型号	Description 描述	Length 长度	Part Number 编号
NA101P 1/4G 接口 Plasma Cutting Torch		6m	NPA0110
NA101P Adaptor 中央插头 Plasma Cutting Torch		6m	NPA0111

Components					
No.	Part Number	Description	No.	Part Number	Description
1	NPC0111	Outside Nozzle 外喷嘴	7	NTP0061	Auto Handle 手柄
2	NPD0101-11	Cutting Tip 60A 电极喷嘴	8	NPH0143	Cable Assembly 6m 电缆总成 6m
	NPD0101-14	Cutting Tip 100A 电极喷嘴	9	NCY0002	Back Cable Support 后尾护套
	NPD0101-17	Cutting Tip 130A 电极喷嘴	10	NBW0195	Back Handle 后枪壳
	NPD0101-19	Cutting Tip 140A 电极喷嘴	11	NBW0174	Locking Nut 中央插头锁母
3	NPE0101	Swirl Ring 涡流环	12	NFY0018G	Central Connector 中央插头
4	NPR0101	Electrode 电极			
5	NFH0562	Cooling Tube 分流气管			
6	NPF0145	Torch Head Kit 枪头			

NO.	Part Number	Description	Φ(mm)	L(mm)	Contact Short	Contact Long	Drag Short	Drag Long	Gouging	Product picture
1	NPC0111	Outside Nozzle		44.1	●					
2	NPD0101-08	Cutting Tip 30A	0.8	13.7	●					
	NPD0101-11	Cutting Tip 60A	1.1	13.7	●					
	NPD0101-14	Cutting Tip 100A	1.4	13.7	●					
	NPD0101-17	Cutting Tip 130A	1.7	13.7	●					
	NPD0101-19	Cutting Tip 140A	1.9	13.7	●					
	NPD0101-30	Gouging	3.0	13.7						
3	NPE0101	Swirl Ring			●					
4	NPR0101	Electrode		22	●					
6	NFH0562	Cooling Tube			●					

● Torch Package Standard Wear Part Set Up 包装标准配件
 Contact Short Contact Long Drag Short Drag Long Gouging

⑧

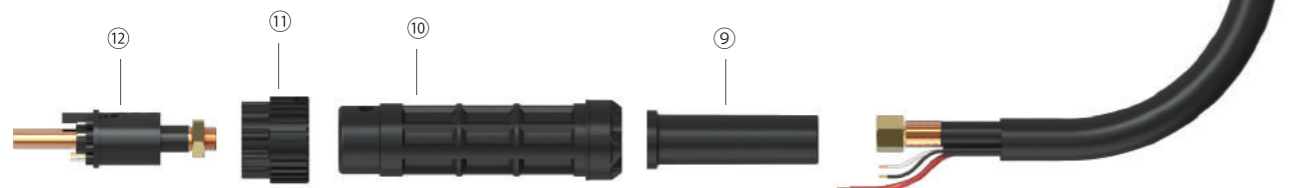

* Denotes Standard Build 表示标准配置, 选配件须注明编号

NA 141P

额定值：140A 60%，100A 100% 暂载率。切割厚度：35-40mm。
 Rating: 140A 60%, 100A 100% duty. Cutting Thickness: 35-40mm.



NA 141P WEAR PARTS

All our consumable parts are interchangeable with the original OEM specification
 Production Materials sourced from qualified top tier supplier (s).

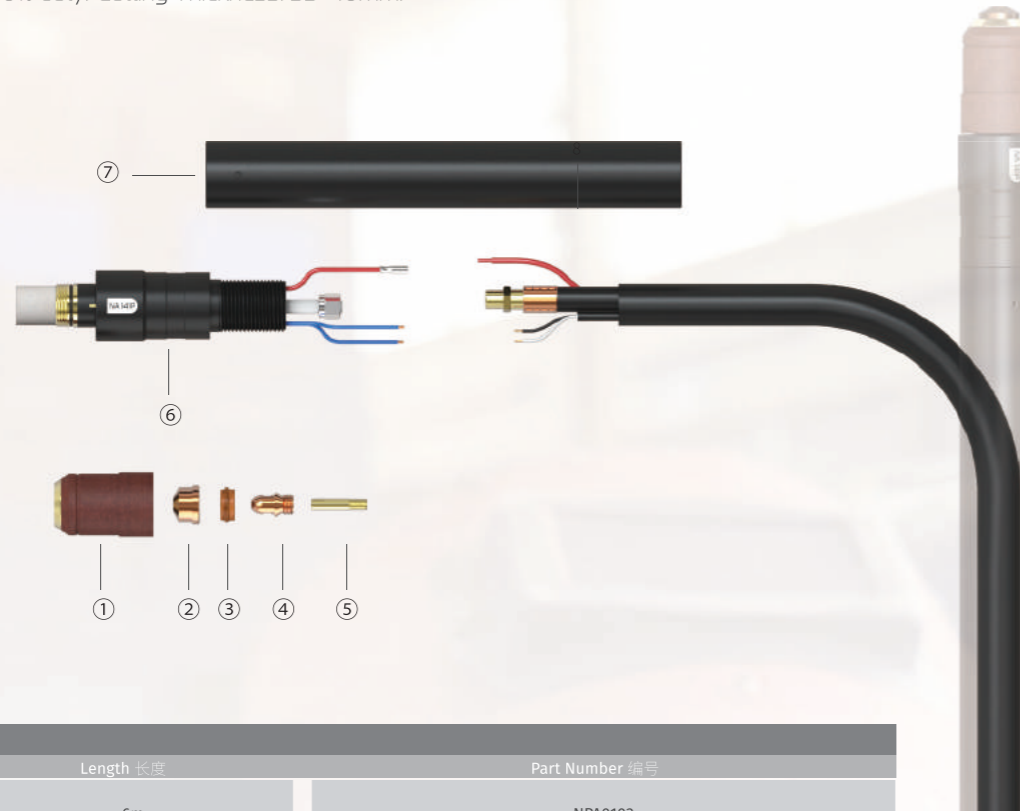

Model 型号	Description 描述	Length 长度	Part Number 编号
NA141P 1/4G 接口 Plasma Cutting Torch		6m	NPA0103
NA141P Adaptor 中央插头 Plasma Cutting Torch		6m	NPA0145

Components					
No.	Part Number	Description	No.	Part Number	Description
1	NPC0102	Outside Nozzle 外喷嘴	7	NTP0061	Auto Handle 手柄
2	NPD0101-11	Cutting Tip 60A 电极喷嘴	8	NPH1171	Cable Assembly 6m 电缆总成 6m
	NPD0101-14	Cutting Tip 100A 电极喷嘴	9	NCY0002	Back Cable Support 后尾护套
	NPD0101-17	Cutting Tip 130A 电极喷嘴	10	NBW0195	Back Handle 后枪壳
	NPD0101-19	Cutting Tip 140A 电极喷嘴	11	NBW0174	Locking Nut 中央插头锁母
3	NPE0101	Swirl Ring 涡流环	12	NFY0018G	Central Connector 中央插头
4	NPR0101	Electrode 电极			
5	NFH0563	Cooling Tube 分流气管			
6	NPF0155	Torch Head Kit 枪头			

NO.	Part Number	Description	Φ(mm)	L(mm)	Contact Short	Contact Long	Drag Short	Drag Long	Gouging	Product picture
1	NPC0102	Outside Nozzle	52.1		●					
2	NPD0101-08	Cutting Tip 30A	0.8	13.7	●					
	NPD0101-11	Cutting Tip 60A	1.1	13.7	●					
	NPD0101-14	Cutting Tip 100A	1.4	13.7	●					
	NPD0101-17	Cutting Tip 130A	1.7	13.7	●					
	NPD0101-19	Cutting Tip 140A	1.9	13.7	●					
	NPD0101-30	Gouging	3.0	13.7						
3	NPE0101	Swirl Ring			●					
4	NPR0101	Electrode		22	●					
6	NFH0563	Cooling Tube			●					

● Torch Package Standard Wear Part Set Up 包装标准配件
 ■ Contact Short ■ Contact Long ■ Drag Short ■ Drag Long ■ Gouging

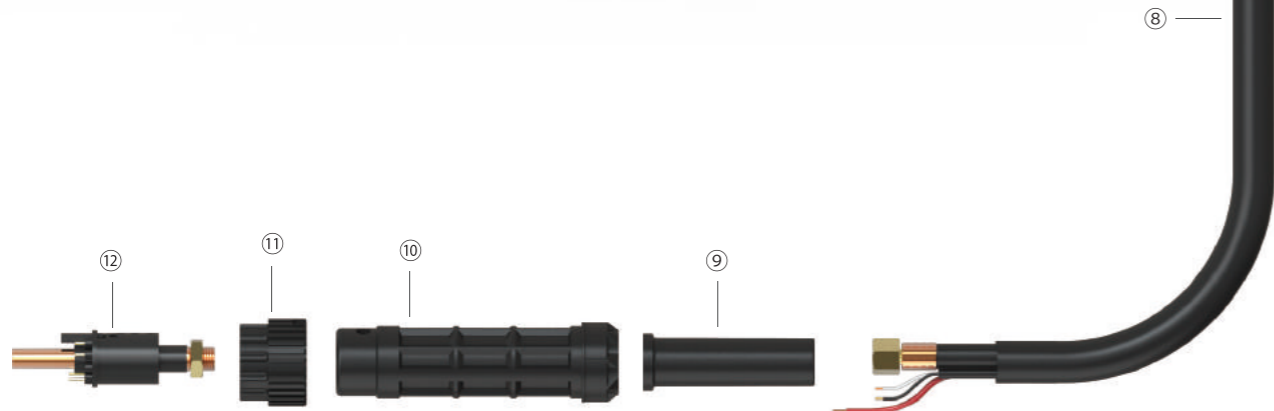

* Denotes Standard Build 表示标准配置，选配件须注明编号

NA 151P

额定值：150A 60%，120A 100% 暂载率。切割厚度：35-40mm。
Rating: 150A 60%, 120A 100% duty. Cutting Thickness: 35-40mm.



NA 151P WEAR PARTS

All our consumable parts are interchangeable with the original OEM specification
Production Materials sourced from qualified top tier supplier (s).



Model 型号	Description 描述	Length 长度	Part Number 编号
NA151P 1/4G 接口 Plasma Cutting Torch		6m	NPA0127
NA151P Adaptor 中央插头 Plasma Cutting Torch		6m	NPA0128

Components					
No.	Part Number	Description	No.	Part Number	Description
1	NPC0120	Outside Nozzle 外喷嘴	7	NTP0061	Auto Handle 手柄
2	NPD0109-11	Cutting Tip 60A 电极喷嘴	8	NPH0171	Cable Assembly 6m 电缆总成 6m
	NPD0109-14	Cutting Tip 100A 电极喷嘴	9	NCY0002	Back Cable Support 后尾护套
	NPD0109-16	Cutting Tip 130A 电极喷嘴	10	NBW0195	Back Handle 后枪壳
	NPD0109-18	Cutting Tip 150A 电极喷嘴	11	NBW0174	Locking Nut 中央插头锁母
3	NPE0103	Swirl Ring 涡流环	12	NFY0018G	Central Connector 中央插头
4	NPR0111	Electrode 电极			
5	NFH0563	Cooling Tube 分流气管			
6	NPF0160	Torch Head Kit 枪头			

NO.	Part Number	Description	Φ(mm)	L(mm)						Product picture
					Contact Short	Contact Long	Drag Short	Drag Long	Gouging	
1	NPC0120	Outside Nozzle	50.9		●					
2	NPD0109-11	Cutting Tip 60A	1.1	12.7	●					
	NPD0109-14	Cutting Tip 100A	1.4	12.7	●					
	NPD0109-16	Cutting Tip 130A	1.6	12.7	●					
	NPD0109-18	Cutting Tip 150A	1.8	12.7	●					
	NPD0109-30	Gouging	3.0	12.7						
3	NPE0103	Swirl Ring			●					
4	NPR0111	Electrode		20.5	●					
5	NFH0563	Cooling Tube			●					

● Torch Package Standard Wear Part Set Up 包装标准配件
 Contact Short Contact Long Drag Short Drag Long Gouging

* Denotes Standard Build 表示标准配置，选配件须注明编号

CBP Range



CNC 精密加工及高质量工程材料。
CNC machined consumables part and aerospace polymers.

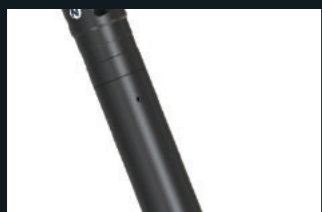

实用、耐用型枪壳。
Solid handle design.

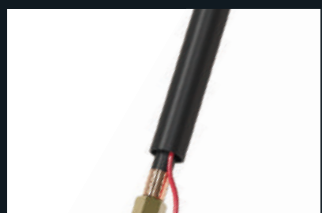

高导电性电缆。
Heavy duty metal jacket with hi conductivity inner copper tube.



可适配多种后尾接头。
Terminations are offered in a "direct to machine" or central connector configuration.

CB 100P



额定值: 100A 60%, 70A 100% 暂载率。切割厚度: 24-30mm。
Rating: 100A 60%, 70A 100% duty. Cutting Thickness: 24-30mm.



Technical Data 参数	CB 100P	CB 150P
Cooling Method 冷却方式	Air-Cooled	Air-Cooled
Rating : 额定电流	100A 70A	150A 110A
Duty Cycle: 暂载率	60% 100%	60% 100%
Cutting Thickness: 切割厚度	24-30mm	35-40mm

High Frequency 高频等离子割枪

Order Part No.	1/4G	4M		
		5M		
		6M	NPA1216	NPA1219
CENTRAL ADAPTOR		4M		
		5M		
		6M	NPA1284	NPA1285

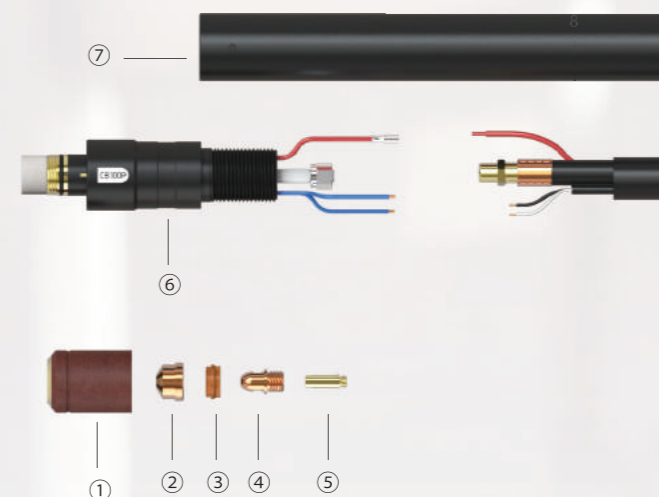

Model 型号	Description 描述	Length 长度	Part Number 编号
CB100P 1/4G 接口 Plasma Cutting Torch		6m	NPA1216
CB100P Adaptor 中央插头 Plasma Cutting Torch		6m	NPA1219

Components					
No.	Part Number	Description	No.	Part Number	Description
1	NPC0037	Outside Nozzle 外喷嘴	6	NPF0075	Torch Head Kit 枪头
2	NPD0026-11	Cutting Tip 60A 电极喷嘴	7	NTP0061	Auto Handle 手柄
	NPD0026-13	Cutting Tip 100A 电极喷嘴	8	NPH1174	Cable Assembly 6m 电缆总成 6m
	NPD0026-16	Cutting Tip 130A 电极喷嘴	9	NCY0002	Back Cable Support 后尾护套
	NPD0026-18	Cutting Tip 150A 电极喷嘴	10	NBW0195	Back Handle 后枪壳
	NPD0026-30	Gouging Tip 气刨喷嘴	11	NBW0174	Locking Nut 中央插头锁母
3	NPE0009	Swirl Ring 涡流环	12	NFY0018G	Central Connector 中央插头
4	NPR0034	Electrode 电极			
5	NFH0214	Cooling Tube 分流气管			

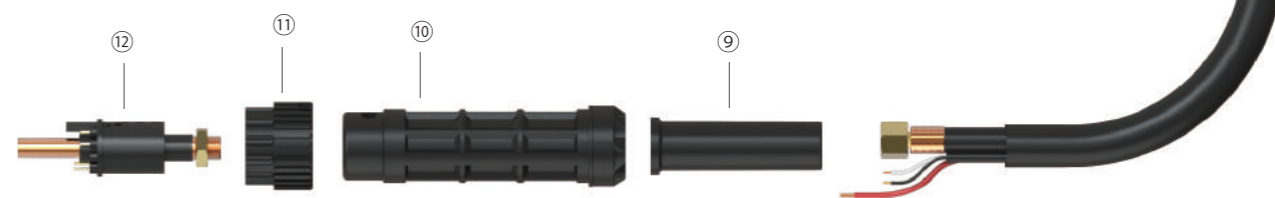





* Denotes Standard Build 表示标准配置, 选配件须注明编号

CB 100P WEAR PARTS

All our consumable parts are interchangeable with the original OEM specification
Production Materials sourced from qualified top tier supplier (S).

NO.	Part Number	Description	Φ(mm)	L(mm)						Product picture	
					Contact Short	Contact Long	Drag Short	Drag Long	Gouging		
1	NPC0037	Outside Nozzle		44.1	●						
2	NPD0026-11	Cutting Tip 60A	1.1	14.1	●						
	NPD0026-13	Cutting Tip 100A	1.3	14.1	●						
	NPD0026-16	Cutting Tip 130A	1.6	14.1	●						
	NPD0026-18	Cutting Tip 150A	1.8	14.1	●						
	NPD0026-30	Gouging	3.0	14.1							
3	NPE0009	Swirl Ring			●						
4	NPR0034	Electrode		22	●						
5	NFH0214	Cooling Tube			●						

● Torch Package Standard Wear Part Set Up 包装标准配件
 Contact Short
 Contact Long
 Drag Short
 Drag Long
 Gouging

CB 150P

额定值: 150A 60%, 110A 100% 暂载率。切割厚度: 35-40mm。
Rating: 150A 60%, 110A 100% duty. Cutting Thickness: 35-40mm.

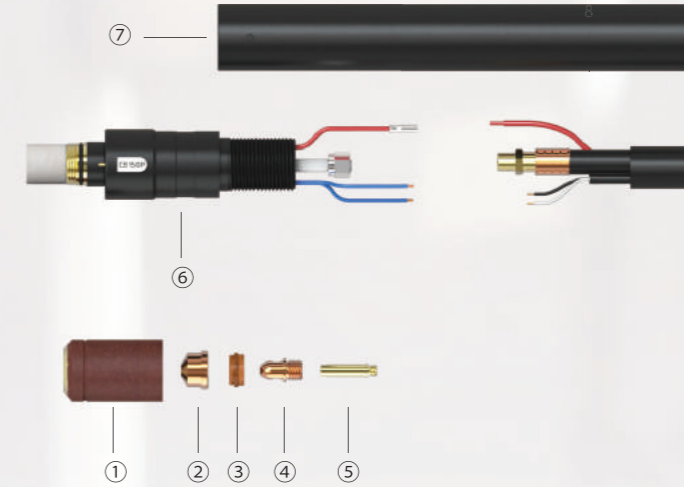

Model 型号		
Description 描述	Length 长度	Part Number 编号
CB150P 1/4G 接口 Plasma Cutting Torch	6m	NPA1284
CB150P Adaptor 中央插头 Plasma Cutting Torch	6m	NPA1285



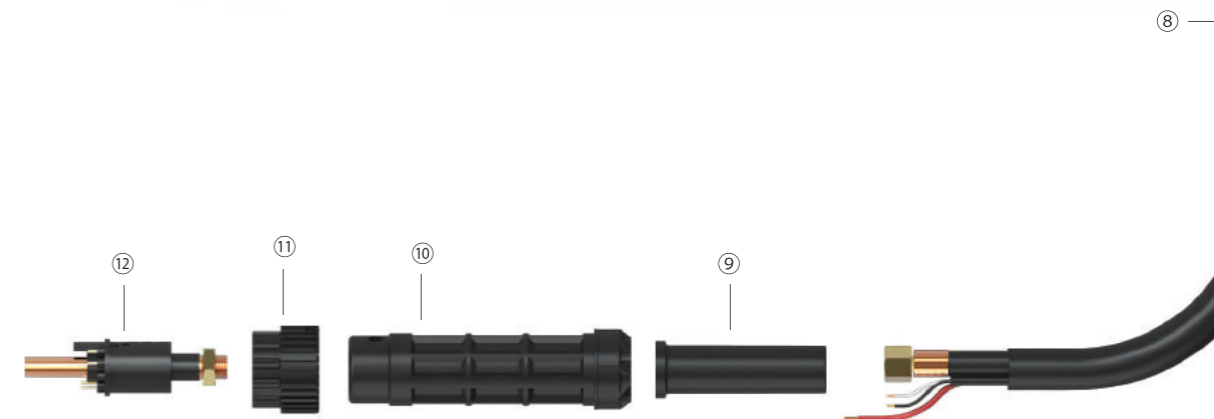

Components					
No.	Part Number	Description	No.	Part Number	Description
1	NPC0002	Outside Nozzle 外喷嘴	6	NPF0080	Torch Head Kit 枪头
2	NPD0026-11	Cutting Tip 60A 电极喷嘴	7	NTP0061	Auto Handle 手柄
	NPD0026-13	Cutting Tip 100A 电极喷嘴	8	NPH1171	Cable Assembly 6m 电缆总成 6m
	NPD0026-16	Cutting Tip 130A 电极喷嘴	9	NCY0002	Back Cable Support 后尾护套
	NPD0026-18	Cutting Tip 150A 电极喷嘴	10	NBW0195	Back Handle 后枪壳
	NPD0026-30	Gouging Tip 气刨喷嘴	11	NBW0174	Locking Nut 中央插头锁母
3	NPE0009	Swirl Ring 涡流环	12	NFY0018G	Central Connector 中央插头
4	NPR0034	Electrode 电极			
5	NFH0213	Cooling Tube 分流气管			

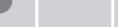

* Denotes Standard Build 表示标准配置, 选配件须注明编号

CB 150P WEAR PARTS

All our consumable parts are interchangeable with the original OEM specification
Production Materials sourced from qualified top tier supplier (s).

NO.	Part Number	Description	Φ(mm)	L(mm)	Contact Short	Contact Long	Drag Short	Drag Long	Gouging	Product picture
1	NPC0002	Outside Nozzle		52.1	●					
2	NPD0026-11	Cutting Tip 60A	1.1	14.1	●					
	NPD0026-13	Cutting Tip 100A	1.3	14.1	●					
	NPD0026-16	Cutting Tip 130A	1.6	14.1	●					
	NPD0026-18	Cutting Tip 150A	1.8	14.1	●					
	NPD0026-30	Gouging	2.4	14.1						
3	NPE0009	Swirl Ring			●					
4	NPR0034	Electrode		22	●					
5	NFH0213	Cooling Tube			●					

● Torch Package Standard Wear Part Set Up 包装标准配件

■ Contact Short ■ Contact Long ■ Drag Short ■ Drag Long ■ Gouging

NW Range

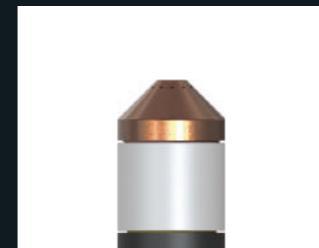

CNC 精密加工及高质量工程材料。
CNC machined consumables part and aerospace polymers.



实用、耐用型枪壳。
Solid handle design.

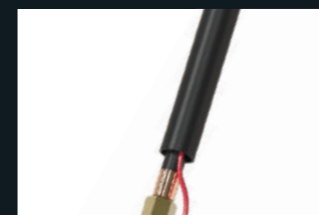

高导电性电缆。
Heavy duty metal jacket with hi conductivity inner copper tube.



可适配多种后尾接头。
Terminations are offered in a "direct to machine" or central connector configuration.



Coming Soon...

Technical Data 参数	NW 130P	NW 160P	NW 200P
Cooling Method 冷却方式			Water-Cooled
Rating : 额定电流			200A
Duty Cycle: 暂载率			100%
Cutting Thickness: 切割厚度			30-75mm

High Frequency 高频等离子割枪

Order Part No.	4M	5M	6M	
				NPA2000

* Denotes Standard Build 表示标准配置，选配件用 注明编号

NW 200P

额定值：200A 100% 暂载率。切割厚度：30-75mm。
 Rating: 200A 100% duty. Cutting Thickness: 30-75mm.

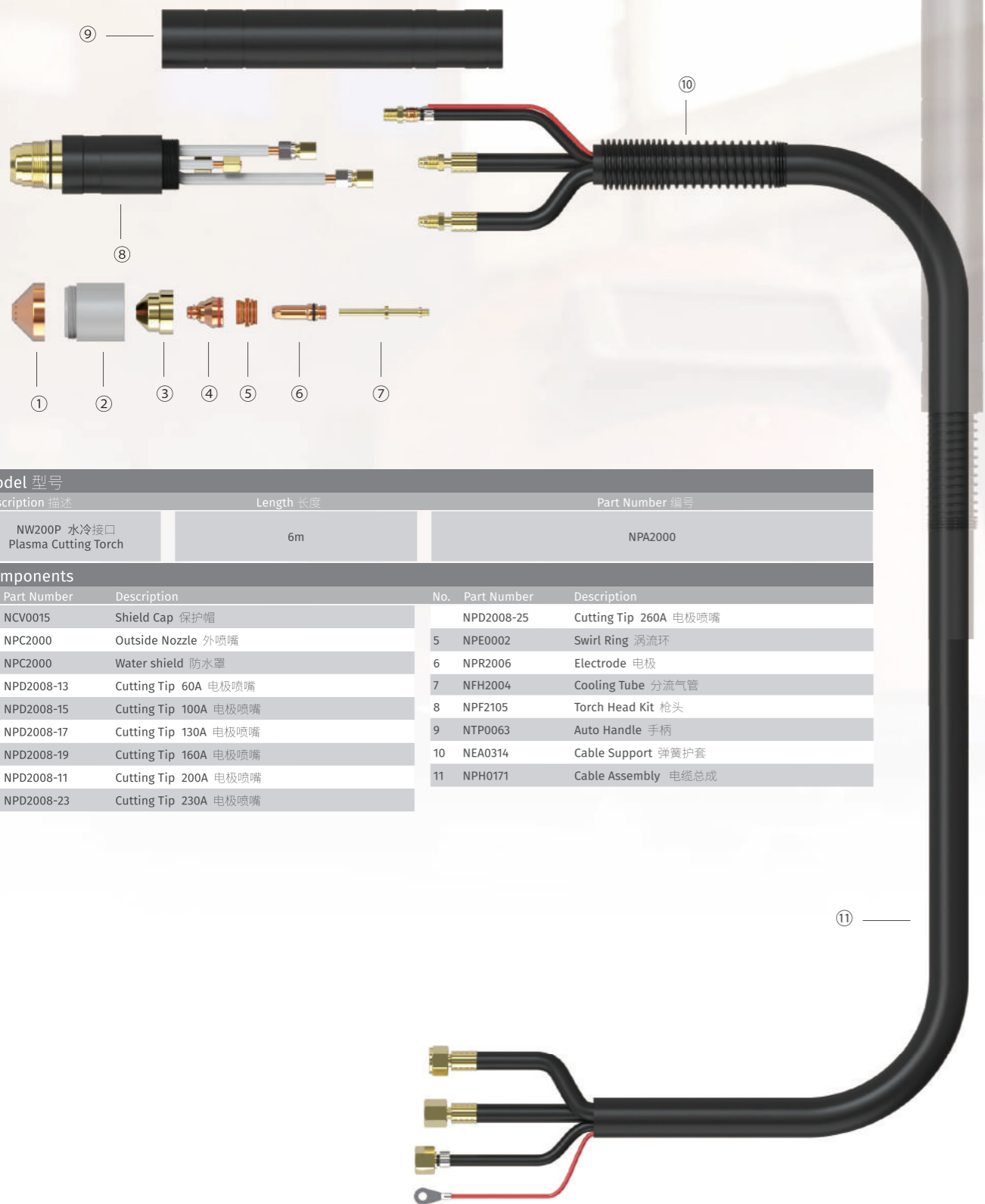

Model 型号		
Description 描述	Length 长度	Part Number 编号
NW200P 水冷接口 Plasma Cutting Torch	6m	NPA2000

Components					
No.	Part Number	Description	No.	Part Number	Description
1	NCV0015	Shield Cap 保护帽	4	NPD2008-13	Cutting Tip 60A 电极喷嘴
2	NPC2000	Outside Nozzle 外喷嘴	4	NPD2008-15	Cutting Tip 100A 电极喷嘴
3	NPC2000	Water shield 防水罩	4	NPD2008-17	Cutting Tip 130A 电极喷嘴
4	NPD2008-13	Cutting Tip 60A 电极喷嘴	4	NPD2008-19	Cutting Tip 160A 电极喷嘴
4	NPD2008-15	Cutting Tip 100A 电极喷嘴	4	NPD2008-11	Cutting Tip 200A 电极喷嘴
4	NPD2008-17	Cutting Tip 130A 电极喷嘴	4	NPD2008-23	Cutting Tip 230A 电极喷嘴
4	NPD2008-19	Cutting Tip 160A 电极喷嘴	5	NPD2008-25	Cutting Tip 260A 电极喷嘴
4	NPD2008-11	Cutting Tip 200A 电极喷嘴	5	NPE0002	Swirl Ring 涡流环
4	NPD2008-23	Cutting Tip 230A 电极喷嘴	6	NPR2006	Electrode 电极
5	NPD2008-25	Cutting Tip 260A 电极喷嘴	6	NPH0171	Cable Assembly 电缆总成
5	NPD2009	Cutting Tip 200A 电极喷嘴	7	NFH2004	Cooling Tube 分流气管
6	NPE0002	Swirl Ring 涡流环	7	NPF2105	Torch Head Kit 枪头
6	NPR2006	Electrode 电极	8	NTP0063	Auto Handle 手柄
7	NFH2004	Cooling Tube 分流气管	9	NEA0314	Cable Support 弹簧护套
			10		
			11		

NW 200P WEAR PARTS

All our consumable parts are interchangeable with the original OEM specification
 Production Materials sourced from qualified top tier supplier (s).

NO.	Part Number	Description	Φ(mm)	L(mm)	Contact Short	Contact Long	Drag Short	Drag Long	Gouging	Product picture
1	NCV0016	Shield Cap	23.2		●					
	NCV0015	Shield Cap	23		●					
2	NPC2000	Outside Nozzle	42		●					
3	NPC2010	Water shield	26		●					
4	NPD2008-13	Cutting Tip 60A	1.3	25.2	●					
	NPD2008-15	Cutting Tip 100A	1.5	25.2	●					
	NPD2008-17	Cutting Tip 130A	1.7	25.2	●					
	NPD2008-19	Cutting Tip 160A	1.9	25.2	●					
	NPD2008-21	Cutting Tip 200A	2.1	25.2	●					
	NPD2008-23	Cutting Tip 230A	2.3	25.2	●					
	NPD2008-25	Cutting Tip 260A	2.5	25.2	●					
5	NPD2009	Cutting Tip 200A		25.2					●	
5	NPE0002	Swirl Ring			●				●	
6	NPR2006	Electrode		37.8	●				●	
7	NFH2004	Cooling Tube			●				●	

● Torch Package Standard Wear Part Set Up 包装标准配件
 Contact Short
 Contact Long
 Drag Short
 Drag Long
 Gouging

* Denotes Standard Build 表示标准配置，选配件须注明编号

Cable and Wiring System

Cable Fitting Options 线缆适配选项

Terminations are offered in a "direct to machine" or central adaptor configuration.
等离子割枪后尾可根据需要选择相应的适配接口。

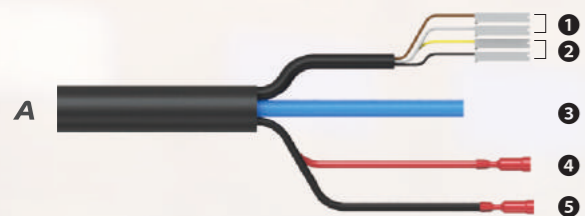

Cable Fitting 线缆适配		
No.	Description	
1	Trigger	扳机控制线
2	Safety	安全保护控制线
3	Gas Tube	气管
4	Pilot arc	引弧线 -6.3 插簧
5	current cable	主电缆 -6.3 插簧

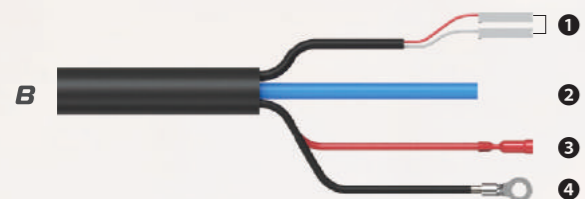

No.	Description	
1	Trigger	扳机控制线
2	Gas Tube	气管
3	Pilot arc	引弧线 -6.3 插簧
4	current cable	主电缆 -OT 端子

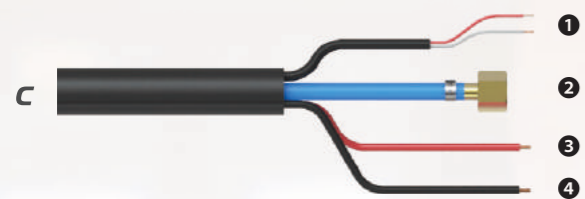

No.	Description	
1	Trigger	扳机控制线
2	1/4 Gas Connector	1/4 气管螺母接头
3	Pilot arc	引弧线
4	current cable	主电缆

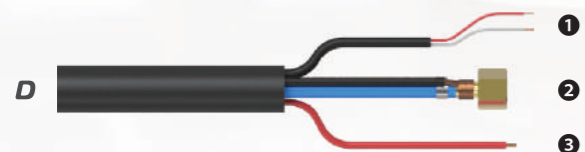

No.	Description	
1	Trigger	扳机控制线 - 可接航插
2	1/4 Gas/Power Connector	1/4 气电一体螺母接头 M16X1.5
3	Pilot arc	引弧线 - 可接 OT 端子
△	低频NS25-NS65后尾接口	



No.	Description	
1	Trigger	扳机控制线 - 可接航插
2	1/4 Gas/Power Connector	1/4 气电一体螺母接头 M16X1.5
		9/16-18UNF / M14X1.5 / M14X1
3	Pilot arc	引弧线 - 可接 OT 端子
△	气电一体后尾接口	



EURO Central Adaptor
欧式中央插头



Miller Central Adaptor
Miller 中央插头

Central Adaptor System 中央插头

If you want to connect a TIG or Plasma torch quickly and safely, the only solution is the North central adaptor system.

- a plastic central body on which 9 different contacts can be mounted.
- a brass pin for the passage of current/gas or air.
- excellent insulation from high frequency current.
- more safely, and more efficient.

诺斯的切割枪中央插头能便捷而且安全的将切割枪连接在切割机上, 并且具有如下几个特点:

1. 有9-pin安全插接触点, 可以根据电源功能搭配不同接线方式, 并保证良好的通信。
2. 可以承载较大电流, 并具有良好的通气能力以及气体密封性。
3. 对高频电流具有良好的阻抗能力。
4. 安装便捷, 使用安全。

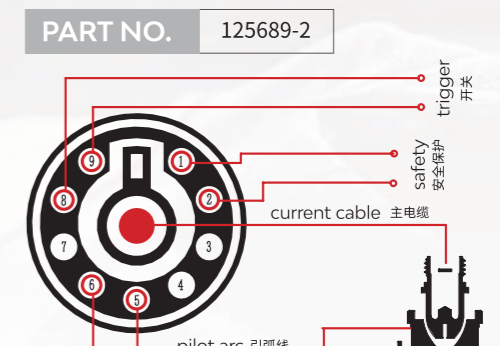
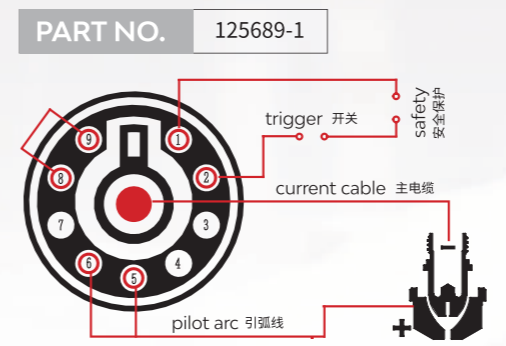
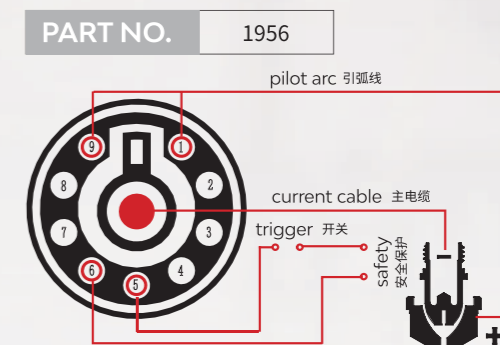
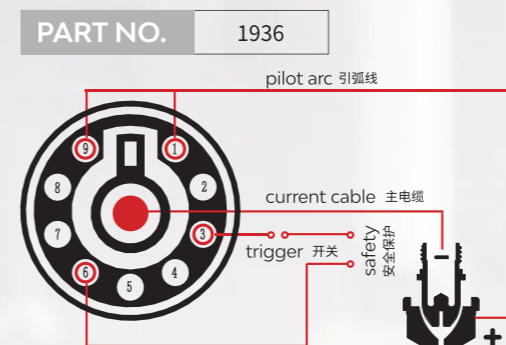

NFY0023 Plasma central adaptor, torch side-Air



NFY0022 Plasma central adaptor, machine side-Air & water



NFY0018 Plasma/Tig central adaptor body-Air



NCV0053 Safety Key



All the operation must be performed by skilled personnel.
所有操作需由一定专业技能的人员来完成。

NOTES

NOTES